



COUNTY OF FLUVANNA, VIRGINIA

Invitation for Bid (IFB) #2017-03

FARM Heritage MUSEUM Barn

Issue Date: April 3, 2017

Due Date: May 5, 2017 at 2 p.m. EST

Procurement & Technical Contact:

County of Fluvanna

Cyndi Toler, Purchasing Officer

132 Main Street

P.O. Box 540

Palmyra, VA 22963

Ph: (434) 591-1930 ext. 1124

Email: ctoler@fluvannacounty.org

All sealed bids shall be turned in no later 2:00 p.m. EST, Friday, May 5, 2017. All bids that are delivered via mail or are hand delivered must be addressed to the "Procurement Contact" listed above. Any Bids that are turned in late will be rejected and returned unopened. Any Bids sent in via facsimile, telephone, or email shall not be considered.

Bid documents may be picked up at the Fluvanna County Department of Finance located at 132 Main Street, 2nd floor, Palmyra, VA 22963 or by clicking on the following link: <http://www.fluvannacounty.org/services/finance/procurement/solicitations>.

1. GENERAL INFORMATION

- A. By this Invitation for Bids ("IFB"), the Fluvanna County Board of Supervisors (hereinafter the "County") is seeking competitive sealed bids from qualified licensed contractors (herein referred to interchangeably as "Contractor" or "Bidder") to establish a firm fixed price contract with Contractor to furnish, deliver, supply and install all necessary labor, and materials associated with the construction of a pre-engineered barn building (the "Barn") and complete any and all necessary or appropriate associated work at the site ("Site Work") in accordance with the specifications, terms and conditions stated herein. Collectively, the work on the Barn and Site Work are referred to herein as the "Project"
- B. The Barn and Site Work will be completed at the property where the Pleasant Grove House and Museum is located known by current street numbering as 271 Pleasant Grove Drive, Palmyra, Virginia 22963 (the "Property"). The Barn shall be located on the Property in the location depicted and as shown in that site plan entitled "Farm Heritage Museum & Parking Lot Improvements" dated December 16, 2016, which is attached hereto and incorporated herein as a material part of this IFB as Exhibit 1 (referred to herein interchangeably as the "Site Plan" or "Exhibit 1"). The building labeled "Farm Heritage Museum" on the Site Plan is the Barn.

2. MANDATORY PRE-BID CONFERENCE

- A. A mandatory pre-bid conference will be held on Wednesday, the 12th day of April 2017 at 10 a.m. at Pleasant Grove House and Museum 271 Pleasant Grove Drive, Palmyra, Virginia 22963.
- B. At the pre-bid conference Bidders will be allowed to inspect and analyze the current environment and collect further data in determination of their ability to perform the work on the Project required. Any Procurement and technical questions shall be directed to Cyndi Toler, Purchasing Officer at ctoler@fluvannacounty.org during the course of this solicitation. The Bidder shall be presumed to have made a reasonable inspection of the premises before the time of Bid submission and shall be held responsible for all information available through such inspections; and submission of a Bid will be a confirmation that the Bidder did make a site inspection and is aware of all conditions affecting performance and price(s) submitted. The County may determine in its sole discretion that a second mandatory pre-bid conference is necessary, the date and time of any such second mandatory pre-bid conference will be disclosed in an amendment to this IFB.

3. SCOPE OF WORK: Contractor shall provide, furnish deliver, supply and install, all necessary or appropriate labor, services, parts, tools, materials, equipment, items and resources as may be required to complete the work on the Project (the "Scope of Work"), in accordance with the specifications and terms and conditions stated herein, which Scope of Work, shall include at minimum, but is not limited to, all of the following:

- A. **Contractor Minimum Requirements:** At minimum the Contractor must meet these minimum performance standards:
 - i. The Contractor should have, at a minimum, a current Class "A" Contractor's license as issued by the Commonwealth of Virginia Board of Contractors, Department of Professional and Occupational Regulation.
 - ii. The Contractor shall possess the appropriate contractor's license with the specific specialty services as recognized by the Virginia Board for Contractors, Department of Professional and Occupational Regulation to perform electrical, roofing and any other services required for the work on the Project.
 - iii. The Contractor's firm should have been in business providing similar services promulgated in this solicitation for a minimum of five (5) consecutive years.
 - iv. The Contractor's personnel assigned to the resulting contract should wear appropriate uniforms or attire that, at a minimum, bear the contractor's company name, the employees name, and shall be maintained in a professional condition at all times.
 - v. The Contractor shall be responsible for providing quality contractor, roofing, electrical and other services required for the performance of any work on the Project in accordance with industry standards, plans, directions and instruction as provided hereunder and in any resulting Contract.
 - vi. All equipment, materials and installation work provided as a part of the Project shall conform to the Virginia Uniform Statewide Building Codes, National Electrical Code, OSHA and the specifications of this IFB.
 - vii. Contractor(s) shall report any safety concerns, near misses, accidents and injuries related to the work area to the County immediately.
 - viii. Contractor(s) shall warrant replace or repair any defective product, materials, installation or services on the Project for five (5) years from County's acceptance of any services hereunder, work or services on the Project at no additional cost. County shall be deemed to have accepted services hereunder only after receipt of a proper and detailed invoice from Contractor for all of the work on the Project and payment by the County to Contractor in full on such invoice.

- ix. Contractor(s) shall respond to emergency warranty repairs within one (1) day and shall respond to routine warranty repairs within three (3) business days.
- x. The Contractor shall transfer and assign to the County any and all warranties or similar guarantees for any materials or products provided by Contractor to the County hereunder.
- xi. Personnel for Electric Services:
 - 1. Contractor(s) shall perform all electrical work on the Project under the supervision of a qualified master electrician. A qualified master electrician shall be a licensed electrician graduated from an accredited school or program and shall have five (5) years plus experience of practical experience in planning, laying out, supervising the installation and repair of wiring, apparatus, or equipment for electrical components regulated by the Building Code and any other applicable electrical regulations. Contractors shall provide a copy of their Class A Electrical Contractor certification and a copy of their Master Electrician license. Contractor(s) shall assure that all employees who will be performing work receive any required training necessary to perform the work. All helpers, assistants, and apprentices shall operate under the supervision of a journeyman or master electrician. The County reserves the right to review any Contractor(s) training documentation.
 - 2. Journeyman Electricians provided by the Contractor should have a minimum of three (3) years of experience performing electrical services in accordance with manufacturer's best practices and must be supervised by a Master Electrician.

B. Building Specifications: At minimum, the Barn and Site Work for the project must meet the following requirements:

- i. Be in all respects consistent with and meet any and all provisions, notes, requirements or specifications shown on that Site Plan attached hereto as Exhibit 1.
- ii. Be in all respects consistent with and meet any and all provisions, notes, requirements or specifications shown on that sketch of the barn entitled "with cupola" which is attached hereto and incorporated herein as a material part of this IFB as Exhibit 2 (hereinafter "Sketch").
- iii. Construct, install, and build a Minimum 36' by 100' (120' is shown in the Sketch, but Contractor's may submit plans for a Barn with the long side being at least 100') building on concrete slab floor.
- iv. Provide all materials, installation, services and labor necessary to pour, lay, install, weather, seal, and if necessary stain the concrete foundation pad and concrete slab with minimum dimensions of 48' by 100' (with the long side actually being at minimum the length of the Barn itself) on which to install the Barn and to accommodate the overhang/porch described herein. The concrete slab must be at least 6 inches thick and structurally sufficient to carry the load of the Barn, farm equipment intended to be stored therein and visitors/staff in the Barn.
- v. The Barn will not be connected to water, is exposed to the elements to the extent of Contractor's design, and shall not be heated or air conditioned. All concrete, electrical fixtures, wiring, buildings, materials and supplies of any kind used in the Project shall be durable and appropriate for the intended uses, weather, conditions, the Barn design and site.
- vi. Necessary or Appropriate fire or other safety alarms and monitoring devices shall be supplied, furnished and installed by the Contractor. At minimum all such devices shall meet requirements of Applicable Law as defined below.
- vii. A minimum 12' wide overhang/porch coming off the Barn along the long side, closest to the road. The entirety of the overhang shall be on the concrete slab. The porch and overhang shall be the same length as the building.
- viii. The North short end of building shall have a 12' by 12' (clear) opening with hinged door(s).

- ix. At minimum, 4 (four) additional openings with hinged doors, minimum 8' wide by 10' high, and 2 pedestrian doors along the long side of the Barn on the side that is closest to the road as depicted more specifically on the attached Sketch, shall be included. One pedestrian door must be on each end of building, appropriately spaced as to not interfere with foot traffic when all doors are open, as shown on the Sketch. All doors shall be in compliance with the Americans with Disabilities Act and Applicable Law as defined below.
- x. Ceiling Height/Interior clearance must be a minimum of 16 feet for farm equipment displays. It is intended that the roof be a pitch roof, with the lowest ceiling clearance being 16 feet, and highest clearance being greater than 16 feet.
- xi. Design must incorporate a period specific-look; the museum will showcase farm equipment from circa 1885 – 1940. The Sketch is a rough draft and only to be used to give contractors an idea of what the County is requesting. When you are submitting a floor plan drawing, it will need to be sufficiently detailed to meet all requirements of Applicable Law as defined below and any permitting requirements.
- xii. Overhead natural light is very important and all designs must incorporate overhead lighting, which may include fixtures, skylights, or other products.
- xiii. Contractor shall install electricity service at the Barn at the appropriate amps for the Barn, but at minimum 100 amp service. Contractor shall provide appropriate Code Compliant grounding of the electrical service and building. Contractor shall coordinate with Central Virginia Electrical Cooperative to determine the route of the incoming electrical service lines. The County prefers the electrical meter to be installed on the right, rear of the building (when facing from the driveway). Contractor shall install all the labor and materials associated with installation of electrical wiring, lighting fixtures, electrical outlets and other electrical appurtenances included in the Project.
- xiv. Lighting fixtures shall be LED weather resistant and shall be sufficient to properly illuminate the space twenty-four hours a day and shall include outdoor lighting and security lighting for safety. Outdoor lighting and security lighting shall have photoelectric controls, as well as being programmable to allow the Owner can set it to turn on and off at specified times. All fixtures shall be period appropriate, excepting security fixtures which shall be concealed to the extent practicable. Fixtures shall be:
 - 1. Period appropriate low wattage display and overhead lights.
 - 2. Period appropriate porch lighting.
 - 3. All fixtures shall have on and off switches.
- xv. Electrical outlets shall be spaced as required by Code. However, there shall be at minimum [24] electrical outlets inside the Barn, with at least [3] outlets on each short side of the Barn and at least [8] outlets on each long side of the barn; and [12] weatherproof outdoor electrical outlets mounted on the exterior walls of the Barn, with at least [1] outlets on each short side of the Barn and at least [5] outlets on each long side of the barn.
- xvi. The Barn must have a Metal Roof with a minimum thirty (30) year warranty.
- xvii. Appropriate ventilation- To allow for natural ventilation, the total net square footage of all building openings - windows, doors, fans, louvers and other openings to the outdoors shall be no less than 4% of the gross floor area of the building per code.
- xviii. Building and the Project shall be code compliant with Applicable law, including the Americans with Disabilities Act.
- xix. The Site Work shall include appropriate low-maintenance drought-resistance landscaping around the Barn, including, but not limited to, sod, perennial plantings, grass, shrubbery, trees, mulching, pebbles or other work as specifically described by the Contractor in any Bid.
- xx. The Barn shall be appropriately insulated.

- xxi. The Barn, with all moveable louvers, windows and doors shut, shall be fully enclosed and with the exception of properly installed passive louvers and roof vents, capable of being sealed off from the outside elements.
- xxii. All windows, doors or other access points to the Barn shall have period-appropriate locking mechanisms installed so that the Barn can be fully locked and sealed.
- xxiii. All windows shall be double-pane, energy efficient and shall come with at least a five (5) year manufacturer's warranty.
- xxiv. All doors shall be exterior doors.
- xxv. Parking lot and sidewalks – Parking spaces, ADA accessible route and signage shall be constructed as shown on the Site Plan and shall be Code compliant.
- xxvi. The Building and Project must be in all respects compliant with the Americans with Disabilities Act and all Applicable Law.

C. ADDITIONAL REQUIREMENTS:

- i. The Contractor shall
 - 1. Assign a Supervisor to the project that shall be the main point of contact for the project.
 - 2. Assure and guaranty that all equipment, materials, and installation work shall conform to the Virginia Uniform Statewide Building Codes, OSHA, and this IFB.
 - 3. Examine the work areas and site conditions under which work stated herein shall be performed. Contractor shall notify County of any condition(s) which may affect installation of building structure.
 - 4. Locate and clearly mark all underground utilities prior to construction.
 - 5. Perform all site preparation work inclusive of soil excavation and rough grade.
 - 6. Provide grade stakes or locator flags to flag corners of building.
 - 7. Obtain building permit.
 - 8. Provide on-site supervision of construction activities.
 - 9. Provide final approval/inspection and acceptance of building structure.
 - 10. Provide finished grading and/or landscape work.
 - 11. Verify site preparation work with a County designated Project Manager.
 - 12. Provide concrete footers and foundation wall with rebar 16" x 24" deep.
 - 13. Deliver building materials to site location as designated by the Project Manager.
 - 14. Erect building.
 - 15. Furnish and install all supplementary or miscellaneous items, appurtenances and devices incidental to or necessary for a sound, secure and complete installation.
 - 16. Provide County with any applicable manufacturer warranties. A copy of these shall be provided with your bid response.
 - 17. Agree to all of the provisions of the County of Fluvanna's General Terms, Conditions and Instructions to Bidders and Contractors attached to this IFB as Appendix I and further shall agree that any resulting contract awarded pursuant to this IFB shall incorporate by reference as material provisions of such Contract the County of Fluvanna's General Terms, Conditions and Instructions to Bidders and Contractors. Any resulting Contract shall be in form acceptable to the County in its sole discretion.

D. PROTECTION OF PERSON AND PROPERTY:

- i. All materials shall be protected from damage during delivery, storage and installation.
- ii. The Contractor shall not remove any excess (unused) construction material from the site without the owner's approval. The owner shall be reimbursed for the unused construction material or keep the material onsite.

- iii. The Contractor is responsible to keep a clean and safe construction area at the end of each work day.
- iv. Contractor shall be responsible for initiating, maintaining and supervision of all safety precautions in connection with the work being performed. Any damage to existing Property, site, buildings, land or personal property, resulting from the Work on the Project or the performance of a Contract awarded pursuant to this IFB shall be repaired or replaced at the sole cost and expense of the Contractor to the satisfaction of the County. The Contractor shall repair and/or replace any damage done to any County property by their employees or resulting from Contractor's services as soon as practicable, but in any event, no more than ten (10) calendar days after notification by the County. All such repairs or replacements shall be completed to the County's sole satisfaction. To protect the Contractor, the Contractor shall document any damages in the project area prior to commencing work. This written record shall be provided to the County prior to commencing work.

E. BUILDING PERMITS & INSPECTIONS:

- i. The Contractor shall notify Miss Utility to locate all underground utilities and their depth and location prior to starting any work on the Project.
- ii. The Contractor shall apply for all required building permits before starting the Work on this project.
- iii. Contractor shall notify the county to arrange for inspections at agreed milestones and shall notify for final inspection.
- iv. Site Plan is attached as Exhibit 1 hereto.

F. INSURANCE REQUIREMENTS:

- i. The firm shall agree to carry the required liability insurances that are listed under item number 39 of the "GENERAL TERMS, CONDITIONS AND INSTRUCTIONS TO BIDDERS AND CONTRACTORS" attached hereto as Appendix I.
- ii. By signing and submitting a proposal under this solicitation, the Contractor certifies that if awarded the contract, it will have the insurance coverage required at the time the work commences. The Contractor further certifies that the contractor will maintain the specified coverage during the entire term of the contract and that all insurance coverage will be provided by insurance companies authorized to sell insurance in Virginia by the Virginia State Corporation Commission.
- iii. During the period of the contract the County reserves the right to require the Contractor to furnish certificates of insurance for the coverage from time to time.
- iv. This is a construction contract under the Virginia Public Procurement Act and Performance and Payment Bonds shall be required pursuant to Virginia Code Section 2.2-4337.

G. APPLICABLE LAW: The Contractor shall comply with applicable federal, State and local laws, ordinances, rules and regulations in performance of the Contract ("Applicable Law") , including, but not limited to:

- i. The Americans with Disabilities Act, as this Project is a new construction Project for a unit of government; and
- ii. The Virginia Statewide Building Code.

H. ALTERNATE PRICING: Please provide alternate pricing removing the concrete foundation pad and slab from under the porch overhang area ONLY (concrete slab still required for Barn) from the scope of work and instead placing the porch area on a graded compressed gravel floor (same dimensions as for the porch overhang). To the extent the Americans with Disabilities Act or Applicable Law requires a sidewalk or other pedestrian access not on gravel, please include that

work in the alternate pricing. If the compressed gravel bed cannot be used under the porch, please note the same in your Bid and the reasons therefore.

4. SUBMITTAL INSTRUCTIONS

- A. The County will not be responsible for any expenses incurred by a firm in preparing and submitting a Bid. All Bids shall provide a straight-forward, concise delineation of the firm's capabilities to satisfy the requirements of this IFB. Emphasis should be on completeness and clarity of content. The contents of the Bid submitted by the successful Bidder and this IFB, and any amendments thereto, will become part of any contract awarded as a result of this IFB.
- B. The format of each bid must contain the following elements organized into separate chapters and sections, as the Bidder may deem appropriate. The following paragraphs provide guidelines to each Bidder for information to include in the bid document:
- C. **Cover Letter** - Provide a cover letter that confirms the Bidder's understanding of this IFB, a general understanding of the project, an overview of the history and qualifications of the firm.
- D. **Overview** - The purpose of this section is to provide Fluvanna County with an overview of the history, qualifications and abilities of the Contractor's firm and for the Contractor to demonstrate the specific qualifications of the staff the Contractor will assign to this Project if selected. At a minimum, the proposal should: (i) Designate a Project Manager and indicate office location; and (ii) Include the organization chart, functional discipline, and responsibilities of Project team members.
- E. **Resumes/Qualifications** - Provide a concise resume or description of each team member's education, relevant professional experience, length of time employed by the Contractor and/or sub-consultant, and professional licenses. Each firm submitting a proposal shall provide an updated statement of qualifications highlighting the expertise and experience of the firm and its personnel related to the Project.
- F. **Demonstrated History of Successful Projects** - Discuss recent project information of similar type to the Project completed by the firm including the project name, location, brief description of the project, description of the scope of services provided, and principal contact person. List all work of a similar nature to the Project completed for any department or agency of the Commonwealth of Virginia and any Virginia public body or locality.
- G. **Proposed Sub-Consultants** - The Contractor shall clearly state whether it is proposing to subcontract any of the work herein. The names of all proposed sub-contractors shall be provided. By proposing such firm(s) or individuals, the Contractor assumes full liability for the sub-consultant's performance. The Contractor shall state the amount of previous work experience with the sub-consultant(s).
- H. **References:** Provide the current name, address, and telephone number of at least five (5) references the Contractor has served either currently or in the past three (3) years; preferably those where one or more of the Project team members provided the same or similar services as requested herein. Indicate the Scope of Services provided to each reference.
- I. **Pricing** – Please provide flat lump sum pricing. The lump sum price shall include all labor, materials, services, equipment, tools, consumables, parts, supervision, permitting, overhead,

administrative, overhead, delivery, shipping, handling, travel and other costs, fees or charges of any kind related to or required for the Work on the Project.

- J. **Project Full Specifications** - Please provide full specifications and features of Barn, landscaping, lighting, materials, concrete, roofing, and all of materials and a detailed listing of all Site Work. Please provide a detailed floor plan. Please provide pictures, pamphlets and materials related to the materials (such as windows, locks, doors, skylights, fans, concrete, finishes, paints, etc.) that will be used.
- K. **Forms:** All forms required to be submitted under this IFB must be included in the Bid.
 - i. Vendor Data Sheet (Attachment A)
 - ii. Proof of Authority to Transact Business in Virginia (Attachment B)
 - iii. Certificate of No Collusion (Attachment C)
 - iv. Bidder Statement (Attachment D)
- L. The County is not responsible for failure to locate, consider and evaluate qualification factors presented outside this format.
- M. Any information thought to be relevant, but not applicable to the enumerated scope of work, should be provided as an appendix to the bid. If publications are supplied by the Officer to respond to a requirement, the response should include reference to the document number and page number. Bids not providing this reference may be considered to have no reference material included in the additional documents.
- N. Each firm submitting a bid shall provide an updated statement of qualifications. The following is the minimum to be considered a complete bid:
 - i. Expertise and experience of the firm related to the scope of services contained in this IFB. This section shall include recent project information of similar type completed by the firm along with the name and telephone number of the point of contact for each project.
 - ii. Financial responsibility of the firm.
 - iii. The firm should include a street address of the office proposed to handle the work.
 - iv. Identification and statement of qualifications of the construction project team who will be assigned to the project for actual "hands on" work, as well as the principal assigned the project for oversight responsibilities.
 - v. Provide your proposed project timeline/completion schedule.
- O. The County is not responsible for failure to locate, consider and evaluate qualification factors presented outside this format.

5. SUBMITTAL INSTRUCTIONS

- A. **Each Bidder must submit one (1) original and four (4) copies along with one (1) electronic copy of its bid documents on CD ROM, DVD, or USB flash drive/memory stick.**
- B. An authorized representative of the Bidder shall sign bid documents. All information requested should be submitted. Failure to submit all information requested may result in the bid being rejected by the County.
- C. All forms attached to this IFB must be fully completed, executed by the Bidder and returned as a part of Offer's Bid.

D. Each bid shall be in writing and received in hard copy by the deadline. Oral bids, bids received by telephone, fax, telegraph, or email shall be rejected.

6. CONTRACT AWARD: The contract will be awarded to the lowest responsible and responsive bidder whose bid, conforming to this IFB, is most advantageous to the County, considering price and any other evaluation criteria set forth in the bid documents and consistent with the Virginia Procurement Act, the County's Code, the County's Procurement Policies and Procedures and other applicable law. Nothing herein requires that the County complete this Work and the County may determine not to award any Contract pursuant to this IFB in its sole discretion for any reason or no reason at all.

7. TERMS

- A. The County's General Terms, Conditions, and Instructions to Bidders and Contractors are attached hereto and incorporated herein by reference as Appendix I. These provisions bind all Bidders. Further, the conditions and requirements of this IFB, including, but not limited to, County's General Terms, Conditions, and Instructions to Bidders and Contractors, are a material part of any contract awarded between the County and the successful Bidder(s).
- B. Awards shall be made to as many Bidders as deemed necessary to fulfill the anticipated requirements of the County. The County may award contracts to multiple Bidders and use their services for some or all of the projects identified herein. The County may choose not to award a contract or Notice to Proceed for any or all projects described herein.

VENDOR DATA SHEET

Note: The following information is required as part of your response to this solicitation. Failure to complete and provide this sheet may result in finding your bid nonresponsive.

1. Qualification: The vendor must have the capability and capacity in all respects to satisfy fully all of the contractual requirements.

2. Vendor's Primary Contact:

Name: _____ Phone: _____

3. Years in Business: Indicate the length of time you have been in business providing this type of good or service:

_____ Years _____ Months

4. Vendor Information:

FIN or FEI Number: _____ If Company, Corporation, or Partnership

5. Indicate below a listing of at least four (4) current or recent accounts, either commercial or governmental, that your company is servicing, has serviced, or has provided similar goods. Include the length of service and the name, address, and telephone number of the point of contact.

Company:	Contact:
Phone:	Email:
Dates of Service:	\$\$ Value:

Company:	Contact:
Phone:	Email:
Dates of Service:	\$\$ Value:

Company:	Contact:
Phone:	Email:
Dates of Service:	\$\$ Value:

Company:	Contact:
Phone:	Email:
Dates of Service:	\$\$ Value:

I certify the accuracy of this information.

Signed: _____ Title: _____ Date: _____

PLEASE RETURN THIS PAGE WITH BID SUBMISSION- (Attachment A)

PROOF OF AUTHORITY TO TRANSACT BUSINESS IN VIRGINIA

THIS FORM MUST BE SUBMITTED WITH YOUR PROPOSAL/BID. FAILURE TO INCLUDE THIS FORM MAY RESULT IN REJECTION OF YOUR PROPOSAL/BID

Pursuant to Virginia Code §2.2-4311.2, an Offeror/Bidder organized or authorized to transact business in The Commonwealth pursuant to Title 13.1 or Title 50 of the Code of Virginia shall include in its proposal/bid the identification number issued to it by the State Corporation Commission (“SCC”). Any Offeror/Bidder that is not required to be authorized to transact business in the Commonwealth as a foreign business entity under Title 13.1 or Title 50 of the Code of Virginia or as otherwise required by law shall include in its proposal/bid a statement describing why the Offeror/Bidder is not required to be so authorized. Any Offeror/Bidder described herein that fails to provide the required information shall not receive an award unless a waiver of this requirement and the administrative policies and procedures established to implement this section is granted by the County Administrator, as applicable. If this quote for goods or services is accepted by the County of Fluvanna, Virginia, the undersigned agrees that the requirements of the Code of Virginia Article IV.2-4311.2 have been met.

Please complete the following by checking the appropriate line that applies and providing the requested information. ***PLEASE NOTE: The SCC number is NOT your federal ID number or business license number.***

A. ____ Offeror/Bidder is a Virginia business entity organized and authorized to transact business in Virginia by the SCC and such vendor’s Identification Number issued to it by the SCC is _____.

B. ____ Offeror/Bidder is an out-of-state (foreign) business entity that is authorized to transact business in Virginia by the SCC and such vendor’s Identification Number issued to it by the SCC is _____.

C. ____ Offeror/Bidder does not have an Identification Number issued to it by the SCC and such vendor is not required to be authorized to transact business in Virginia by the SCC for the following reason(s):

Please attach additional sheets if you need to explain why such Offeror/Bidder is not required to be authorized to transact business in Virginia.

Legal Name of Company (as listed on W-9)

Legal Name of Offeror/Bidder

Date

Authorized Signature

Print or Type Name and Title

PLEASE RETURN THIS PAGE WITH BID SUBMISSION (Attachment B)

CERTIFICATION OF NO COLLUSION

The undersigned, acting on behalf of _____, does hereby certify in connection with the procurement and bid to which this Certification of No Collusion is attached that:

This bid is not the result of, or affected by, any act of collusion with another person engaged in the same line of business or commerce: nor is this bid the result of, or affected by, any act of fraud punishable under Article 1.1 of Chapter 12 of Title 18.2 Code of Virginia, 1950 as amended (&&18.2-498.1 et seq.)

Signature of Company Representative

Name of Company

Date

ACKNOWLEDGEMENT

STATE OF VIRGINIA
FLUVANNA COUNTY, to wit:

The foregoing Certification of No Collusion bearing the signature of _____ and dated _____ was subscribed and sworn to before the undersigned notary public by _____ on _____.

Notary Public

My commission expires: _____

CODE OF VIRGINIA

& 18.2-498.4. Duty to provide certified statement:

A. The Commonwealth, or any department or agency thereof, and any local government or any department or agency thereof, may require that any person seeking, offering or agreeing to transact business or commerce with it, or seeking, offering or agreeing to receive any portion of the public funds or moneys, submit a certification that the offer or agreement or any claim resulting thereon is not the result of, or affected by, any act of collusion with another person engaged in the same line of business or commerce, or any act of fraud punishable under this article.

B. Any person required to submit a certified statement as provided in paragraph A, above who knowingly makes a false statement shall be guilty of a Class 6 felony. (1980, c.472)

a false statement shall be guilty of a Class 6 felony. (1980, c.472)

PLEASE RETURN THIS PAGE WITH BID SUBMISSION- (Attachment C)

OFFEROR STATEMENT

Undersigned Bidder hereby certifies that he/she has carefully examined all conditions and specifications of this invitation for Bid and hereby submits this bid pursuant to such instructions and instructions.

Type or Print Name & Title of Authorized Person

Signature of Authorized Person Submitting This Bid

Date

SUBSCRIBED AND SWORN to before me by the above named

_____ on the ____ day of _____, 2013

Notary Public in and for the State of _____

My commission expires: _____

PLEASE RETURN THIS PAGE WITH BID SUBMISSION- (Attachment D)

EROSION & SEDIMENT CONTROL LEGEND

No.	TITLE	KEY	SYMBOL
3.02	TEMPORARY STONE CONSTRUCTION ENTRANCE	(CE)	
3.05	SILT FENCE	(SF)	
3.07	STORM DRAIN INLET PROTECTION	(IP)	
3.17	STORMWATER CONVEYANCE CHANNEL	(SCC)	
3.18	OUTLET PROTECTION	(OP)	
3.20	ROCK CHECK DAM	(CD)	
3.21	LEVEL SPREADER	(LS)	
3.30	TOPSOILING	(TO)	
3.31	TEMPORARY SEEDING (THROUGHOUT UNPAVED AREAS W/IN LIMITS OF DISTURBANCE)	(TS)	
3.32	PERMANENT SEEDING (THROUGHOUT UNPAVED AREAS W/IN LIMITS OF DISTURBANCE)	(PS)	
3.35	MULCHING (THROUGHOUT UNPAVED AREAS W/IN LIMITS OF DISTURBANCE)	(MU)	
3.36	SOIL STABILIZATION BLANKETS & MATTING	(B/M)	
3.39	DUST CONTROL (ENTIRE AREA W/IN LIMITS OF DISTURBANCE)	(DC)	

PAVEMENT & DEMOLITION LEGEND

- GRAVEL PARKING AND PATH (SEE SECTION, SHEET C5.1)
- REMOVE WOODEN WHEEL STOPS

GRADING LEGEND

- SW: GRAVEL PATH ELEVATION
- INV: SMALE INVERT ELEVATION
- G: GROUND ELEVATION
- P: GRAVEL ROAD/PARKING ELEVATION
- ME: MATCH EXISTING ELEVATION
- E: APPROXIMATE EXISTING ELEVATION, CONTACT ENGINEER FOR ACTUAL FIELD ELEVATION VARIES BY 4"±

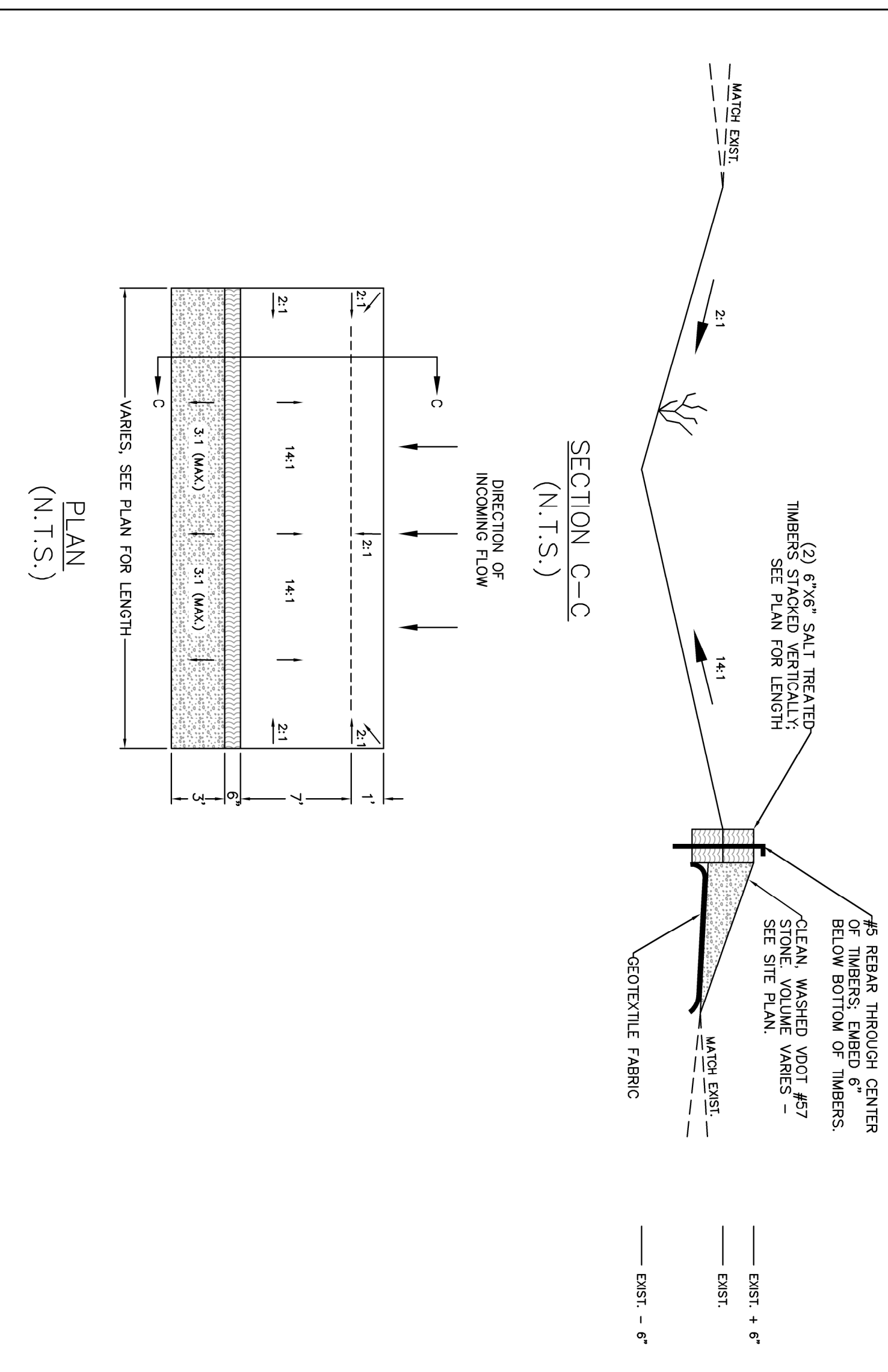

ENGINEERED LEVEL SPREADER (VESCH SECT. 3.21; VA DEQ STORMWATER DESIGN SPEC. NO. 2)

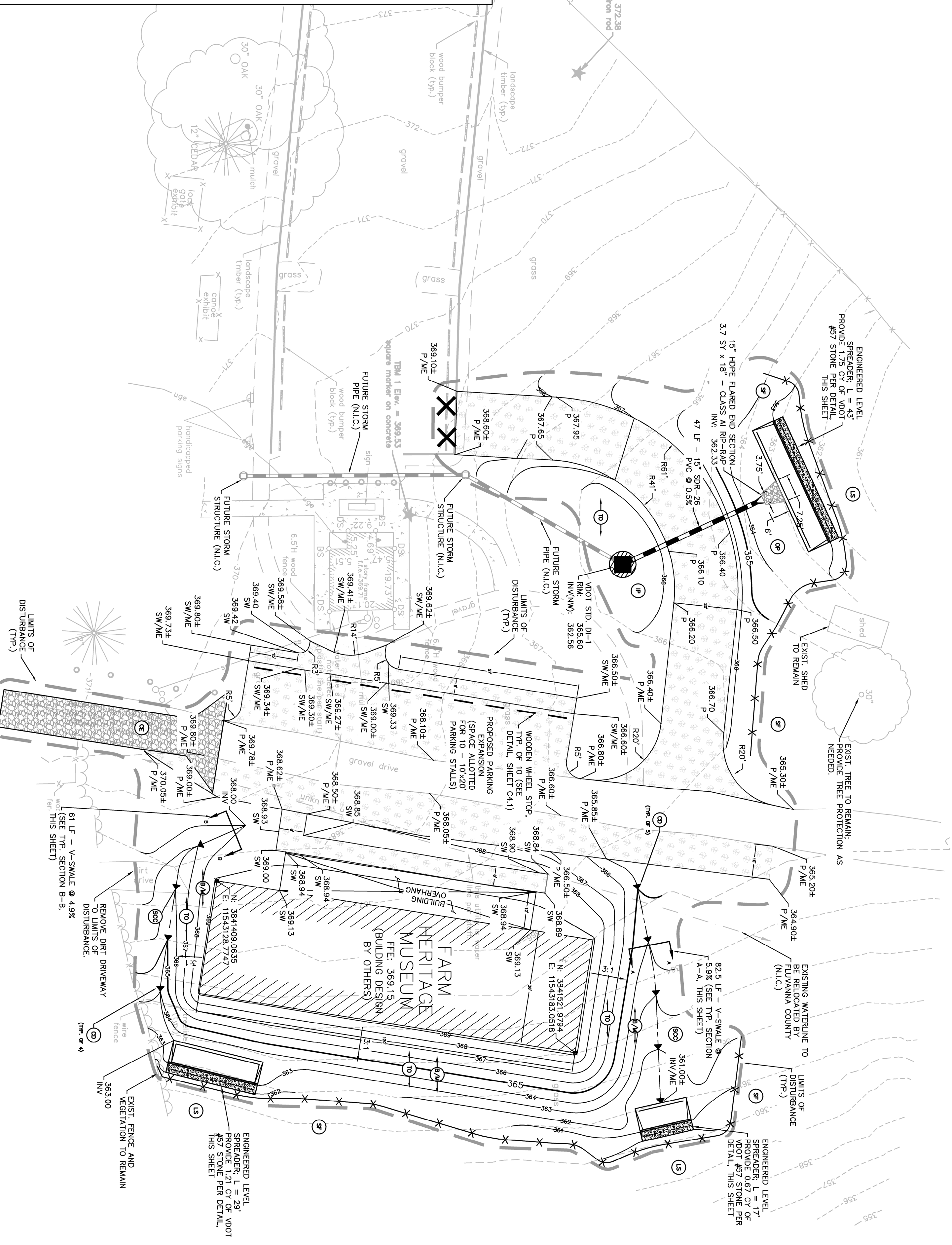

SITE PLAN
FARM HERITAGE MUSEUM & PARKING LOT IMPROVEMENTS
 PALMYRA, VIRGINIA

Draper Aden Associates
 Engineering • Surveying • Environmental Services

Charlottesville, VA 110 Avon Street Charlottesville, VA 22902 434-295-0700 Fax: 434-295-2105 www.daa.com

Richmond, VA • Blacksburg, VA • Hampton Roads, VA • Coats, NC • Fayetteville, NC • Northern Virginia

DESIGNED BY: CAH
 DRAWN BY: CEP
 CHECKED BY: CAH
 SCALE: 1" = 20'
 DATE: DECEMBER 16, 2016
 PROJECT NUMBER: R13457C-11
C3.0

REVISIONS

STORMWATER CONVEYANCE CHANNEL TYPICAL SECTION A-A (N.T.S.)

STORMWATER CONVEYANCE CHANNEL TYPICAL SECTION B-B (N.T.S.)

GRAPHIC SCALE (IN FEET) 1 inch = 20 ft

with Cupola

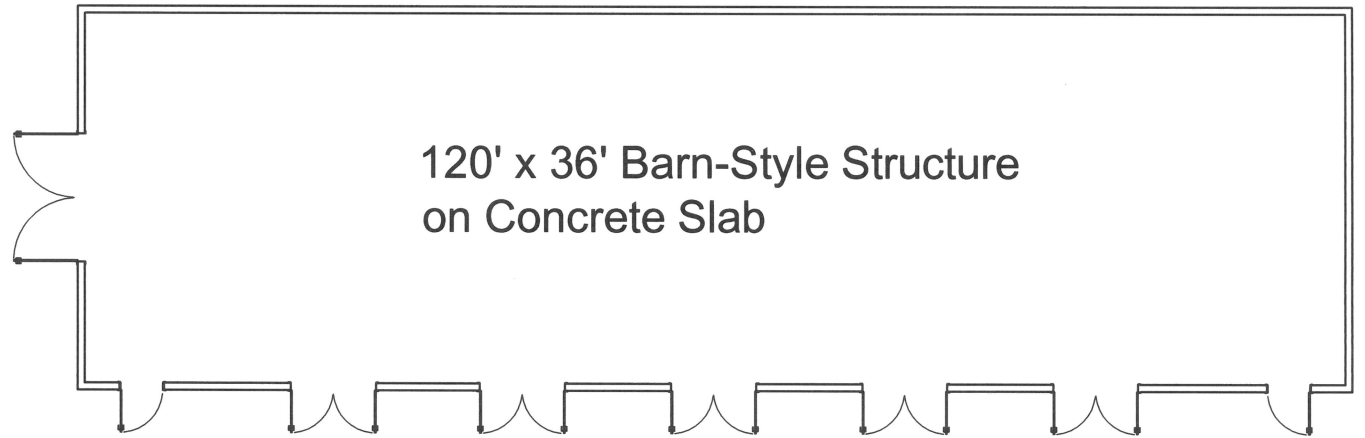

DRAFT

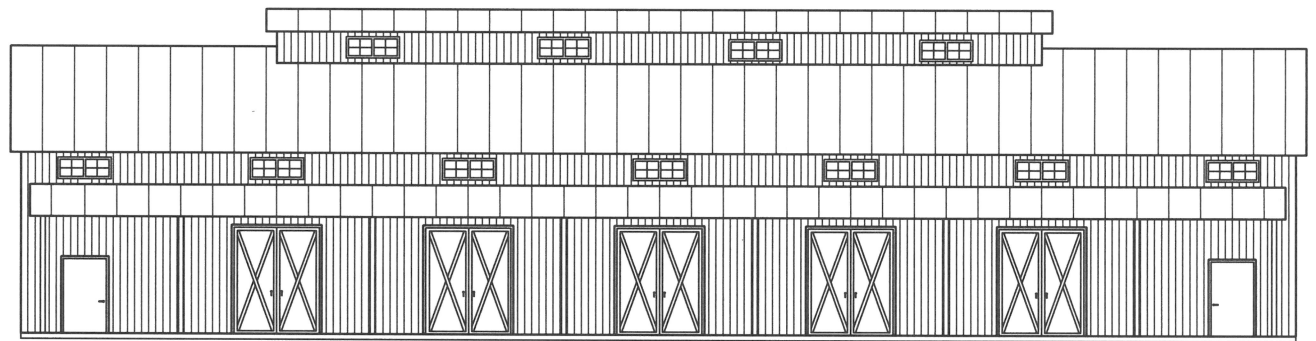
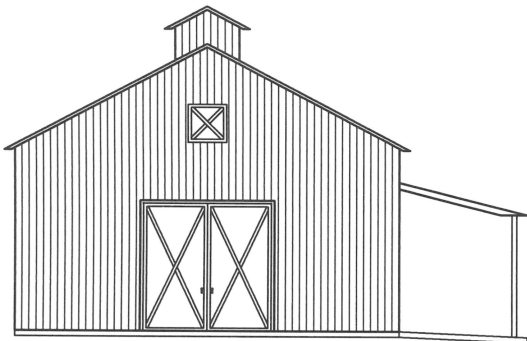

with Ridge Vent

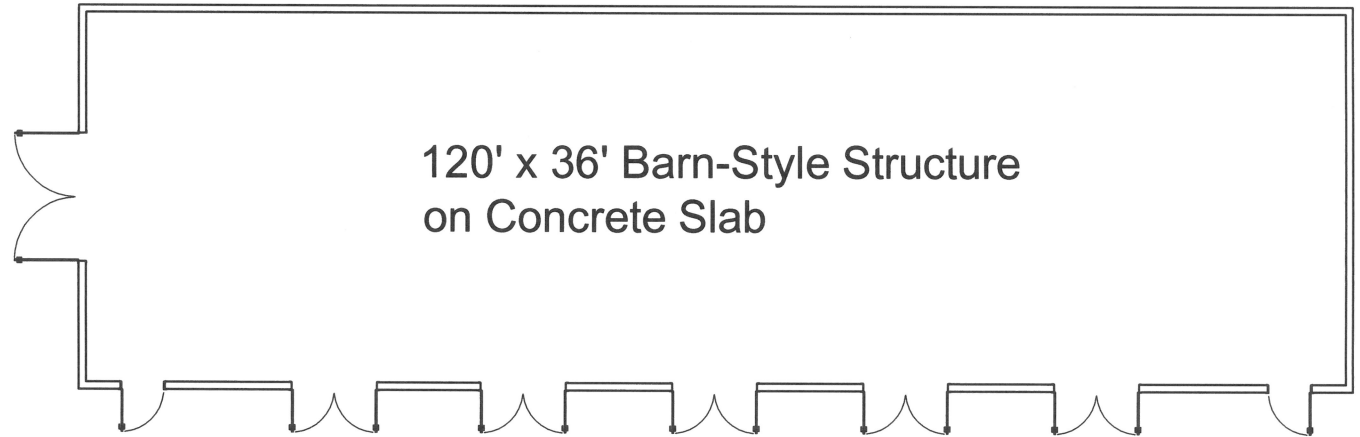

DRAFT

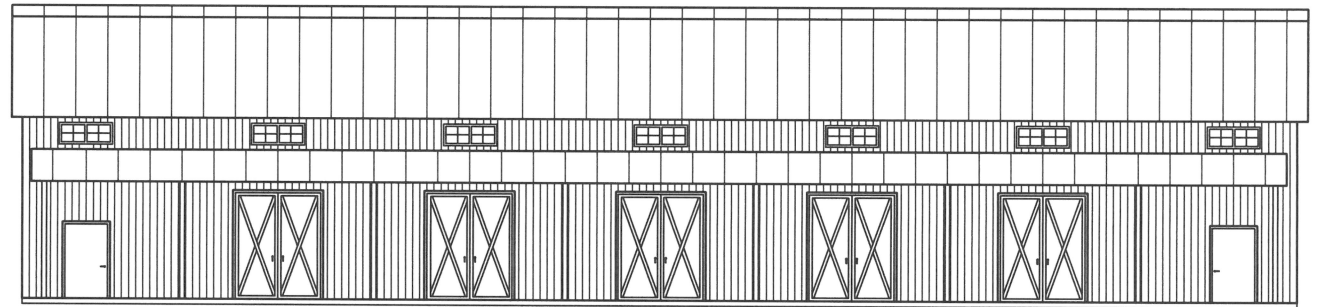
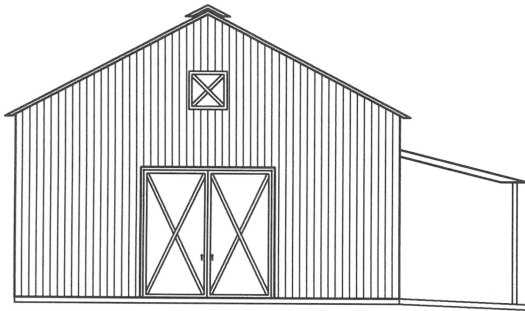

Appendix I

COUNTY OF FLUVANNA

GENERAL TERMS, CONDITIONS AND INSTRUCTIONS TO BIDDERS AND CONTRACTORS

GENERAL TERMS, CONDITIONS AND INSTRUCTIONS TO BIDDERS AND CONTRACTORS

These General Terms, Conditions and Instructions to Bidders and Contractor (hereinafter referred to as the “General Conditions”) shall apply to all purchases and be incorporated into and be a part of each Solicitation (as defined below) and every Contract (as defined below) awarded by Fluvanna County, a political subdivision of the Commonwealth of Virginia (hereinafter referred to as the “County”) unless otherwise specified by the County in writing. Bidders, Offerors and Contractors or their authorized representatives are expected to inform themselves fully as to these General Conditions before submitting Bids or Proposals to and/or entering into any Contract with the County: failure to do so will be at the Bidder’s/Contractor’s own risk and except as provided by law, relief cannot be secured on the plea of error.

Subject to all Federal, State and local laws, policies, resolutions, regulations, rules, limitations and legislation, including the County’s Procurement Policies and Procedures, Bids or Proposals on all Solicitations issued by County will bind Bidders or Offerors, as applicable, and Contracts will bind Contractors, to all applicable terms, conditions, instructions, rules and requirements herein set forth unless otherwise SPECIFICALLY set forth by the County in writing in the Solicitation or Contract. All provisions of these General Conditions are material to any contract between the County and a Contractor.

INTRODUCTION

- 1. VIRGINIA PUBLIC PROCUREMENT ACT AND ETHICS IN PUBLIC CONTRACTING:** The Virginia Public Procurement Act of Virginia Code §§ 2.2-4300 *et seq.* (hereinafter the “VPPA”) is incorporated herein by reference. Nothing in these General Conditions is intended to conflict with the VPPA and in case of any conflict, the VPPA controls. Specifically, the provisions of Article 6 of the VPPA (Virginia Code §§ 2.2-4367 through 2.2-4377) relating to ethics in contracting, shall be applicable to all Solicitations and Contracts solicited or entered into by the County. By submitting their Bids or signing any Contract, all Bidders and Contractors certify that they have not violated any of the provisions of Article 6 of the VPPA, including, but not limited to, that their Bids are made without collusion or fraud and that they have not offered or received any kickbacks or inducements.

- 2. DEFINITIONS:** The definitions of Virginia Code §§ 2.2-4301, 2.2-4302.1 and 2.2-4302.2 are specifically incorporated herein by reference and as used in these General Conditions, whether capitalized or not, any of such defined terms have the same meaning as such terms have under the VPPA: such defined terms include: “Affiliate”, “Best Value”, “Business”, “Competitive Negotiation”, “Competitive Sealed Bidding”, “Construction”, “Construction Management Contract”, “Design-Build Contract”, “Employment Services Organization”, “Goods”, “Informality”, “Job Order Contracting”, “Multiphase Professional Services Contract”, “Nonprofessional Services”, “Potential Bidder or Offeror”, “Professional Services”, “Public Body”, “Public Contract”, “Responsible Bidder or Offeror”, “Responsive Bidder”, “Reverse Auctioning” and

“Services”. Additionally, as used in these General Conditions, the following terms, whether capitalized or not, have the following meanings:

- a. Bid/Proposal: The offer of a Bidder or Offeror to provide specific Goods or Services at specified prices and/or other conditions specified in the Solicitation. The term “Bid” is used throughout these General Conditions and where appropriate includes the term “Proposal” or any modifications or amendments to any Bid or Proposal.
- b. Bidder/Offeror/Vendor: Any individual(s), company, firm, corporation, partnership or other organization bidding or offering on any Solicitation issued by the County and/or offering to enter into Contracts with the County. The term “Bidder” is used throughout these General Conditions and where appropriate includes the term “Offeror” and/or “Vendor”.
- c. Contract: Any contract to which the County will be a party.
- d. Contractor: Any individual(s), company, firm, corporation, partnership, or other organization to whom an award is made by the County or whom enters into any contract to which the County is a party.
- e. County: The County of Fluvanna, a political subdivision of the Commonwealth of Virginia, including where applicable all agencies and departments of the County.
- f. County Administrator: The Fluvanna County Administrator.
- g. County Attorney: The Fluvanna County Attorney.
- h. Purchasing Agent: The County Administrator is the County’s Purchasing Agent and is responsible for the purchasing activity of Fluvanna County; and has signatory authority to bind the County to all contracts and purchases made lawfully under the Fluvanna County Small Purchasing Procedures. The Purchasing Agent has signatory authority to bind the County to all other contracts and purchases only after the contracts or purchases have been approved by a vote of the Fluvanna County Board of Supervisors.
- i. General Terms, Conditions and Instructions to Bidders and Contractors (also referred to herein as the “General Conditions”): These General Terms, Conditions and Instructions to Bidders and Contractors shall be attached to and made a part of all Solicitations by the County and all Contracts to which the County is party.
- j. His: Any references to “his” shall include his, her, their, or its as appropriate.
- k. Invitation to Bid (also referred to herein as an “IFB”): A request which is made to prospective Bidders for their quotation on Goods or Services desired by the County. The issuance of an IFB will contain or incorporate by reference the General Conditions and the other specifications and contractual terms and

conditions applicable to the procurement.

- l. Purchasing Officer: The Purchasing Officer employed by the County and to whom Bidders/Contractors can submit questions relating to any Bid or Contract.
 - m. Request for Proposal (also referred to herein as a “RFP”): A request for an offer from prospective Offerors which shall indicate the general terms which are sought to be procured from Offerors. The RFP will specify the evaluation factors to be used and will contain or incorporate by reference the General Conditions and other applicable contractual terms and conditions, including any unique capabilities or qualifications that will be required of the Contractor.
 - n. Small Purchasing Procedures: The County’s Small Purchasing Procedures, being Chapter 4 of the County’s Procurement Policies and Procedures, a method of purchasing not requiring competitive sealed bids or competitive negotiation for single or term contracts for goods and services other than professional services if the aggregate or the sum of all phases is not expected to exceed \$50,000; and also allowing for single or term contracts for professional services without requiring competitive negotiation, provided the aggregate or the sum of all phases is not expected to exceed \$50,000.
 - o. Solicitation: The process of notifying prospective Bidders or Offerors that the County wishes to receive Bids or Proposals on a set of requirements to provide Goods or Services. “Solicitation” includes any notification of the County requirements may consist of public advertising (newspaper, County’s website, or other electronic notification), the mailing of notices of Solicitation, any Invitation for Quotes (“IFQ”), Initiations to Bid (“IFB”), or Requests for Proposal (“RFP”), the public posting of notices, issuance of an Open Market Procurement (“OMP”), or telephone calls to prospective Bidders or Offerors.
 - p. State: The Commonwealth of Virginia.
3. **AUTHORITY**: The Purchasing Agent shall serve as the principal public purchasing official for the County, and shall be responsible for the procurement of goods, services, insurance and construction in accordance with the County’s Procurement Policies and Procedures. The Purchasing Agent has responsibility and authority for negotiating, placing and when necessary modifying every Solicitation, Contract and purchase order issued by the County under the County’s Small Purchasing Procedures. The Purchasing Agent has signatory authority to bind the County to all contracts and purchases made lawfully under the County’s Small Purchasing Procedures. The Purchasing Agent has responsibility and authority for negotiating, placing and when necessary modifying every other Solicitation, Contract and purchase order issued by the County except that the Purchasing Agent has signatory authority to bind the County to all other contracts and purchases ONLY after the contracts or purchases have been adopted and approved by a vote of the Fluvanna County Board of Supervisors (the “Board”).

Unless specifically delegated by the Board or the Purchasing Agent, and consistent with the limited authority granted thereto, no other County officer or employee is authorized to order supplies or Services, enter into purchase negotiations or Contracts, or in any way obligate the County for any indebtedness. Any purchase or contract made which is contrary to such authority shall be of no effect and void and the County shall not be bound thereby.

For convenience, the County's Purchasing Officer shall serve as an intermediary between the Purchasing Agent and the Bidder or Contractor and any Bidder or Contractor may direct communications regarding any purchase, Solicitation or Contract to the Purchasing Officer; however as stated *supra* only the Board or County's Purchasing Agent can bind the County and only upon the conditions stated *supra*.

CONDITIONS OF BIDDING

- 4. COMPETITION INTENDED:** It is the County's intent to encourage and permit open and competitive bidding in all Solicitations. It shall be the Bidder's responsibility to advise the County in writing if any language, requirement, specification, etc., or any combination thereof, stifles competition or inadvertently restricts or limits the requirements stated in a Solicitation to a single source. The County must receive such notification not later than seven (7) business days prior to the deadline set for acceptance of the Bids. In submitting a Bid, the Bidder guarantees that he or she has not been a party with other Bidders to an agreement to bid a fixed or uniform price. Violation of this implied guarantee shall render the Bid of any Bidder involved void.
- 5. DISCRIMINATION PROHIBITED:** Pursuant to Virginia Code § 2.2-4310, the County does not discriminate against Bidders, Offerors or Contractors because of race, religion, color, sex, national origin, age, disability, status as a service disabled veteran, or any other basis prohibited by state law relating to discrimination in employment. Whenever solicitations are made, the County shall include businesses selected from a list made available by the Department of Small Business and Supplier Diversity. Pursuant to Virginia Code § 2.2-4343.1, the County does not discriminate against "faith-based organizations", being a religious organization that is or applies to be a contractor to provide goods or services for programs funded by the block grant provided pursuant to the Personal Responsibility and Work Reconciliation Act of 1996, P.L. 104-193.
- 6. CLARIFICATION OF TERMS:** Pursuant to Virginia Code § 2.2-4316, if any Bidder has questions or comments about the specifications or other Solicitation documents, the prospective Bidder should contact the County no later than seven (7) business days prior to the date set for the opening of Bids or receipt of Proposals. Any revisions to the Solicitation will be made only by written addendum issued by the County. Notifications regarding specifications may not be considered if received in less than seven (7) business days of the date set for opening of Bids/receipt of Proposals.
- 7. MANDATORY USE OF COUNTY FORM AND TERMS AND CONDITIONS:** Unless otherwise specified in the Solicitation, all Bids must be submitted on the forms

provided by the County, including but not limited to, a Cover Sheet or Pricing Schedule, if applicable, properly signed in ink in the proper spaces and submitted in a sealed envelope or package. Unauthorized modification of or additions to any portion of the Solicitation may be cause for rejection of the Bid. However, the County reserves the right to decide, on a case by case basis, in its sole discretion, whether to reject any Bid or Proposal which has been modified. These General Conditions are mandatory provisions of all Solicitations and all Contracts of the County.

8. LATE BIDS & MODIFICATION OF BIDS: Any Bid or modification thereto received at the office designated in the Solicitation after the exact time specified for receipt of the Bid is considered a late Bid or modification thereof. The County is not responsible for delays in the delivery of the mail by the U.S. Postal Service, private carriers or the inter-office mail system. It is the sole responsibility of the Bidder to ensure their Bid reaches County by the designated date and hour. The following rules apply to all Bids submitted to the County:

- a. The official time used in the receipt of Bids/Proposals is that time on the automatic time stamp machine in the Finance Department;
- b. Late Bids or modifications thereof will be returned to the Bidder UNOPENED, if Solicitation number, due date and Bidder's return address is shown on the container;
- c. If a Bid is submitted on time, however a modification thereto is submitted after the due date and time, then the County in its sole discretion may choose to consider the original Bid except that the County may not consider such original Bid if the Bid is withdrawn by the Bidder pursuant to Section 9 below; and
- d. If an emergency or unanticipated event or closing interrupts or suspends the County's normal business operations so that Bids cannot be received by the exact time specified in the Solicitation, then the due date/time specified for receipt of Bids will be deemed to be extended to the same time of day specified in the Solicitation on the first work day on which normal County business operations resume.

9. WITHDRAWAL OF BIDS:

- a. Pursuant to Virginia Code § 2.2-4330, a Bidder for a public construction contract, other than a contract for construction or maintenance of public highways, may withdraw his Bid from consideration if the price bid was substantially lower than the other Bids due solely to a mistake in the Bid, provided the Bid was submitted in good faith, and the mistake was a clerical mistake as opposed to a judgment mistake, and was actually due to an unintentional arithmetic error or an unintentional omission of a quantity of work, labor or material made directly in the compilation of a Bid, which unintentional arithmetic error or unintentional omission can be clearly shown by objective evidence drawn from inspection of original work papers, documents and materials used in the preparation of the Bid sought to be withdrawn.

If a Bid contains both clerical and judgment mistakes, a Bidder may withdraw his Bid from consideration if the price bid would have been substantially lower than the other Bids due solely to the clerical mistake, that was an unintentional arithmetic error or an unintentional omission of a quantity of work, labor or material made directly in the compilation of a Bid that shall be clearly shown by objective evidence drawn from inspection of original work papers, documents and materials used in the preparation of the Bid sought to be withdrawn. The Bidder shall give notice in writing to the County of his or her claim of right to withdraw his or her Bid within two (2) business days after the conclusion of the Bid opening procedure and shall submit original work papers with such notice.

- b. A Bidder for a Contract other than for public construction may request withdrawal of his or her Bid under the following circumstances:
 - i. Bids may be withdrawn on written request from the Bidder received at the address shown in the Solicitation prior to the time of opening.
 - ii. Requests for withdrawal of Bids after opening of such Bids but prior to award shall be transmitted to the County, in writing, accompanied by full documentation supporting the request. If the request is based on a claim of error, documentation must show the basis of the error. Such documentation may take the form of supplier quotations, Bidder work sheets, etc. If Bid bonds were tendered with the Bid, the County may exercise its right of collection.
- c. No Bid may be withdrawn under this Section 9 when the result would be the awarding of the Contract on another Bid of the same Bidder or of another Bidder in which the ownership of the withdrawing Bidder is more than five percent (5%).
- d. If a Bid is withdrawn under the authority of this Section 9 the lowest remaining Bid shall be deemed to be the low Bid.
- e. No Bidder who, is permitted to withdraw a Bid shall, for compensation, supply any material or labor to or perform any subcontract or other work agreement for the person or firm to whom the Contract is awarded or otherwise benefit, directly or indirectly, from the performance of the project for which the withdrawn Bid was submitted.
- f. The County shall notify the Bidder in writing within five (5) business days of its decision regarding the Bidder's request to withdraw its Bid. If the County denies the withdrawal of a Bid under the provisions of this Section 9, it shall State in such notice the reasons for its decision and award the Contract to such Bidder at the Bid price, provided such Bidder is a responsible and responsive Bidder. At the same time that the notice is provided, the County shall return all work papers and copies thereof that have been submitted by the Bidder.

- g. Under these procedures, a mistake shall be proved only from the original work papers, documents and materials delivered as required herein. The work papers, documents and materials submitted by the bidder shall, at the bidder's request, be considered trade secrets or proprietary information subject to the conditions of subsection F of Virginia Code § 2.2-4342.

10. ERRORS IN BIDS: When an error is made in extending total prices, the unit Bid price will govern. Erasures in Bids must be initialed by the Bidder. Carelessness in quoting prices, or otherwise in preparation of the Bid, will not relieve the Bidder. Bidders/Offerors are cautioned to recheck their Bids for possible error. Errors discovered after public opening cannot be corrected and the Bidder will be required to perform if his or her Bid is accepted.

11. IDENTIFICATION ON BID ENVELOPE: All Bids, Proposals and requested copies thereof submitted to the County shall be in a separate envelope or package, sealed and identified with the following information clearly marked on the outside of the envelope or package:

- a. Addressed as indicated on page 1 of the solicitation;
- b. Solicitation number;
- c. Title;
- d. Bid due date and time;
- e. Bidder's name and complete mailing address (return address); and
- f. Pursuant to Virginia Code § 2.2-4311.2, the Bidder's identification number issued by the State Corporation Commission, or if the bidder is not required to be authorized to transact business in the Commonwealth as a foreign business entity under Title 13.1 or Title 50 or as otherwise required by law shall include in its bids or proposal a statement describing why the bidder or offeror is not required to be so authorized.

If a Bid is not addressed with the information as shown above, the Bidder takes the risk that the envelope may be inadvertently opened and the information compromised, which may cause the Bid to be disqualified. Bids may be hand delivered to the designated location in the County's offices. No other correspondence or other Proposals/Bids should be placed in the envelope. Any Bidder or Offeror that fails to provide the information required in (f) above shall not receive an award unless a waiver is specifically granted by the County Administrator.

12. ACCEPTANCE OF BIDS: Unless otherwise specified, all formal Bids or Proposals submitted shall be valid for a minimum period of one hundred twenty (120) calendar days following the date established for opening or receipt, respectively, unless extend by mutual agreement of the parties. At the end of the one hundred twenty (120) calendar days the Bid/Proposal may be withdrawn at the written request of the Bidder. Thereafter, unless and until the Proposal is withdrawn, it remains in effect until an award is made or the Solicitation is canceled by the County. The County may cancel any Solicitation at any time by notice of such cancelation to the Bidders.

- 13. COMPLETENESS:** To be responsive, a Bid must include all information required by the Solicitation.
- 14. CONDITIONAL BIDS:** Conditional Bids are subject to rejection in whole or in part.
- 15. RESPONSE TO SOLICITATIONS:** In the event a Bidder cannot submit a Bid on a Solicitation, the Bidder is requested to return the Solicitation cover sheet with an explanation as to why the Bidder is unable to Bid on these requirements, or if there be no cover sheet for the Solicitation a letter to the County explaining the same.
- 16. BIDDER INTERESTED IN MORE THAN ONE BID AND COLLUSION:** More than one bid from an individual, firm, partnership, corporation or association under the same or different name will be rejected. Reasonable grounds for believing that a bidder is interested in more than one bid for the work contemplated will cause rejection of all bids in which the bidder is interested. Any or all bids may be rejected if there is any reason for believing that collusion exists among the bidders. Participants in such collusion may not be considered in future bids for the same work. Each bidder, as a condition of submitting a bid, shall certify that he is not a party to any collusive action as herein defined. However, a party who has quoted prices on work, materials, or supplies to a Bidder is not thereby disqualified from quoting prices to other Bidders or firms submitting a Bid directly for the work, materials or supplies.
- 17. BID OPENING:** Pursuant to Virginia Code § 2.2-4301, all Bids received in response to an IFB will be opened at the date, time and place specified, and announced publicly, and made available for inspection as provided in Section 21 of these General Conditions. Proposals received in response to an RFP will be made available for inspection as provided in Section 21 of these General Conditions.
- 18. TAX EXEMPTION:** The County is exempt from the payment of any federal excise or any Virginia sales tax. The price bid must be net, exclusive of taxes. Tax exemption certificates will be furnished if requested by the Bidder.
- 19. DEBARMENT STATUS:** By submitting their Bids, Bidders certify that they are not currently debarred from submitting Bids on Contracts by the County, nor are they an agent of any person or entity that is currently debarred from submitting Bids or Proposals on Contracts by the County or any agency, public entity/locality or authority of the State.
- 20. NO CONTACT POLICY:** No Bidder shall initiate or otherwise have contact related to the Solicitation with any County representative or employee, other than the Purchasing Officer or Purchasing Agent, after the date and time established for receipt of Bids. Any contact initiated by a Bidder with any County representative, other than the Purchasing Officer or Purchasing Agent, concerning this Solicitation is prohibited and may cause the disqualification of the Bidder.

21. VIRGINIA FREEDOM OF INFORMATION ACT: As provided under Virginia Code § 2.2-4342, all proceedings, records, Contracts and other public records relating to procurement transactions shall be open to the inspection of any citizen, or any interested person, firm or corporation, in accordance with the Virginia Freedom of Information Act of Virginia Code §§ 2.2-3700 *et seq.*, except:

- a. Cost estimates relating to a proposed procurement transaction prepared by or for the County shall not be open to public inspection;
- b. Any competitive sealed bidding Bidder, upon request, shall be afforded the opportunity to inspect Bid records within a reasonable time after the opening of Bids but prior to award, except in the event that the County decides not to accept any of the Bids and to reopen the Contract. Otherwise, Bid records shall be open to public inspection only after award of the Contract;
- c. Any competitive negotiation Offeror, upon request, shall be afforded the opportunity to inspect Proposal records within a reasonable time after the evaluation and negotiations of Proposals are completed but prior to award except in the event that the County decides not to accept any of the Proposals and to reopen the Contract. Otherwise, Proposal records shall be open to the public inspection only after award of the Contract;
- d. Any inspection of procurement transaction records under this Section 21 shall be subject to reasonable restrictions to ensure the security and integrity of the records;
- e. Trade secrets or proprietary information submitted by a Bidder, Offeror or Contractor in connection with a procurement transaction shall not be subject to public disclosure under the Virginia Freedom of Information Act; however, the Bidder, Offeror or Contractor must invoke the protections of this Section 21 prior to or upon submission of the data or other materials, and must identify the data or other materials to be protected and State the reasons why protection is necessary; and
- f. Nothing contained in this Section 21 shall be construed to require the County, when procuring by “competitive negotiation” (RFP), to furnish a Statement of reasons why a particular Proposal was not deemed to be the most advantageous to the County.

22. CONFLICT OF INTEREST: Bidder/Contractor certifies by signing any Bid/Contract to/with the County that no conflict of interest exists between Bidder/Contractor and County that interferes with fair competition and no conflict of interest exists between Bidder/Contractor and any other person or organization that constitutes a conflict of interest with respect to the Bid/Contract with the County.

SPECIFICATIONS

23. OMISSIONS OR DISCREPANCIES: Any items or parts of any equipment listed in a Solicitation which are not fully described or are omitted from such specification, and which are clearly necessary for the completion of such equipment and its appurtenances, shall be considered a part of such equipment although not directly specified or called for

in the specifications. Should a Bidder find a discrepancy or ambiguity in, or an omission from, the Solicitation, including the drawings and/or specifications, he or she shall so notify the County within twenty-four (24) hours of noting the discrepancy, ambiguity or omission and in any event no less than five (5) days prior to the date set for the opening of Bids. If necessary, the County will send a written addendum for clarification to all Bidders no later than three (3) days before the date set for opening of Bids. Any notification regarding specifications received less than five (5) days prior to the date set for the opening of Bids may or may not be considered by the County in its sole discretion. The Bidder shall abide by and comply with the true intent of the specifications and not take advantage of any unintentional error or omission, but shall fully complete every part as the true intent and meaning of the specifications and drawings. Whenever the mention is made of any articles, material or workmanship to be in accordance with laws, ordinances, building codes, underwriter's codes, A.S.T.M. regulations or similar expressions, the requirements of these laws, ordinances, etc., shall be construed as to the minimum requirements of these specifications.

24. BRAND NAME OR EQUAL ITEMS: Pursuant to Virginia Code § 2.2-4315, unless otherwise provided in the Solicitation, the name of a certain brand, make or manufacturer does not restrict Bidders to the specific brand, make or manufacturer named; it conveys the general style, type, character, and quality of the article desired, and any article which the County in its sole discretion determines to be the equal of that specified, considering quality, workmanship, economy of operation, and suitability for the purpose intended, shall be accepted. The Bidder is responsible to clearly and specifically indicate the product being offered and to provide sufficient descriptive literature, catalog cuts and technical detail to enable the County to determine if the product offered meets the requirements of the Solicitation. This is required even if offering the exact brand, make or manufacturer specified. Normally in competitive sealed bidding, only the information furnished with the Bid will be considered in the evaluation. Failure to furnish adequate data for evaluation purposes may result in declaring a Bid non-responsive. Unless the Bidder clearly indicates in its Bid that the product offered is "equal" product, such Bid will be considered to offer the brand name product referenced in the Solicitation.

25. FORMAL SPECIFICATIONS: When a Solicitation contains a specification which states no substitutes, no deviation therefrom will be permitted and the Bidder will be required to furnish articles in conformity with that specification.

26. CONDITION OF ITEMS: Unless otherwise specified in the Solicitation, all items shall be new, in first class condition.

AWARD

27. RESPONSIBLE BIDDERS: In determining whether a Bidder is a responsible Bidder as defined herein, at minimum, the following criteria will be considered:

- a. The ability, capacity and skill of the Bidder to perform the Contract or provide the service required under the Solicitation;

- b. Whether the Bidder can perform the Contract or provide the service promptly, or within the time specified, without delay or interference;
- c. The character, integrity, reputation, judgment, experience and efficiency of the Bidder;
- d. The quality of performance of previous Contracts or Services;
- e. The previous and existing compliance by the Bidder with laws and ordinances relating to the Contract or Services;
- f. The sufficiency of the financial resources and ability of the Bidder to perform the Contract or provide the service;
- g. The quality, availability and adaptability of the Goods or Services to the particular use required;
- h. The ability of the Bidder to provide future maintenance and service for the use of the subject of the Contract;
- i. The number and scope of the conditions attached to the Bid;
- j. Whether the Bidder is in arrears to the County on debt or Contract or is a defaulter on surety to the County or whether the Bidder's County taxes or assessments are delinquent; and
- k. Such other information as may be secured by the County, the Purchasing Agent or the Purchasing Officer having a bearing on the decision to award the Contract. If an apparent low Bidder is not awarded a Contract for reasons of nonresponsibility, the County shall so notify that Bidder and shall have recorded the reasons in the Solicitation or Contract file.

28. AWARD OR REJECTION OF BIDS; WAIVER OF INFORMALITIES: The County shall award the Contract to the lowest responsive and responsible Bidder complying with all provisions of the IFB, provided the Bid price is reasonable and it is in the best interest of the County to accept it. Awards made in response to a RFP will be made to the highest qualified Offeror whose Proposal is determined, in writing, to be the most advantageous to the County taking into consideration the evaluation factors set forth in the RFP. The County reserves the right to award a Contract by individual items, in the aggregate, or in combination thereof, or to reject any or all Bids and to waive any informality in Bids received whenever such rejection or waiver is in the best interest of the County. Award may be made to as many Bidders/Offerors as deemed necessary to fulfill the anticipated requirements of the County. The County also reserves the right to reject the Bid if a Bidder is deemed to be a non-responsible Bidder. Pursuant to Virginia Code § 2.2-4319, an IFB, a RFP, any other solicitation, or any and all bids or proposals, may be canceled or rejected by the County at any time. The reasons for cancellation or rejection shall be made part of the contract file. The County shall not cancel or reject an IFB, a RFP, any other solicitation, bid or proposal solely to avoid awarding a contract to a particular responsive and responsible bidder or offeror.

29. EXCLUSION OF INSURANCE BIDS PROHIBITED: Pursuant to Virginia Code § 2.2-4320, notwithstanding any other provision of law or these General Conditions, no insurer licensed to transact the business of insurance in the State or approved to issue surplus lines insurance in the State shall be excluded from presenting an insurance bid proposal to the County in response to a RFP or an IFB; excepting that the County may

debar a prospective insurer pursuant to its Debarment Policy, see Chapter 2 of the County's Procurement Policies and Procedures.

30. ANNOUNCEMENT OF AWARD: Upon the award or announcement of the decision to award a Contract as a result of this Solicitation, the County will publicly post such notice on the County's bulletin board located at 72 Main Street, 2nd Floor, Palmyra, Virginia 22963. Award results may also be viewed on the County's website.

31. QUALIFICATIONS OF BIDDERS OR OFFERORS: The County may make such reasonable investigations as deemed proper and necessary to determine the ability of the Bidder to perform the work/furnish the item(s) and the Bidder shall furnish to the County all such information and data for this purpose as may be requested. The County reserves the right to inspect Bidder's physical facilities prior to award to satisfy questions regarding the Bidder's capabilities. The County further reserves the right to reject any Bid or Proposal if the evidence submitted by or investigations of, such Bidder fails to satisfy the County that such Bidder is properly qualified to carry out the obligations of the Contract and to complete the work/furnish the item(s) contemplated therein.

32. TIE BIDS AND PREFERENCE FOR VIRGINIA PRODUCTS WITH RECYCLED CONTENT AND FOR VIRGINIA FIRMS:

- a. Pursuant to Virginia Code § 2.2-4328, in the case of a tie bid on an IFB only, the County may give preference to Goods, Services and construction produced in Fluvanna County or provided by persons, firms or corporations having principal places of business in Fluvanna County. If such choice is not available, preference shall then be given to Goods produced in Virginia, or for goods, services or construction provided by Virginia persons, firms, corporations, pursuant Virginia Code § 2.2-4324. If no County or State choice is available, the tie shall be decided publicly by lot. The decision by the County to make award to one or more such Bidders shall be final.
- b. Whenever the lowest responsive and responsible bidder is a resident of any other state and such state under its laws allows a resident contractor of that state a percentage preference, a like preference shall be allowed to the lowest responsive and responsible bidder who is a resident of Virginia and is the next lowest bidder. If the lowest responsive and responsible bidder is a resident of any other state and such state under its laws allows a resident contractor of that state a price-matching preference, a like preference shall be allowed to responsive and responsible bidders who are residents of Virginia. If the lowest bidder is a resident contractor of a state with an absolute preference, the bid shall not be considered. The Department of General Services shall post and maintain an updated list on its website of all states with an absolute preference for their resident contractors and those states that allow their resident contractors a percentage preference, including the respective percentage amounts. For purposes of compliance with this Section 32, the County may rely upon the accuracy of the information posted on this website.
- c. Notwithstanding the provisions of subsections a and b, in the case of a tie bid in instances where goods are being offered, and existing price preferences have

already been taken into account, preference shall be given to the bidder whose goods contain the greatest amount of recycled content.

- d. For the purposes of this Section 32, a Virginia person, firm or corporation shall be deemed to be a resident of Virginia if such person, firm or corporation has been organized pursuant to Virginia law or maintains a principal place of business within Virginia.

33. NEGOTIATION WITH LOWEST RESPONSIBLE BIDDER: Pursuant to Virginia Code § 2.2-4318, unless cancelled or rejected, a responsive Bid from the lowest responsible Bidder shall be accepted as submitted, except that if the Bid from the lowest responsible Bidder exceeds available funds, the County may negotiate with the apparent low Bidder to obtain a Contract price within available funds. However, the negotiation may be undertaken only under conditions and procedures described in writing and approved by the County prior to issuance of the IFB and summarized therein.

CONTRACT PROVISIONS

34. APPLICABLE LAW AND COURTS: Any Bid or Contract resulting from a Solicitation and its terms, including, but not limited to, the parties' obligations under it, and the remedies available to each party for breach of it, shall be governed by, construed and interpreted in accordance with the laws of the Commonwealth of Virginia, and exclusive jurisdiction and venue of any dispute or matters involving litigation between the parties hereto shall be in the courts of Fluvanna County, Virginia. Any jurisdiction's choice of law, conflict of laws, rules, or provisions, including those of the Commonwealth of Virginia, that would cause the application of any laws other than those of the Commonwealth of Virginia, shall not apply. The Contractor shall comply with applicable federal, State and local laws, ordinances, rules and regulations in performance of the Contract.

35. PROVISION AND OWNERSHIP OF INFORMATION: The County shall make a good faith effort to identify and make available to the Contractor all non-confidential technical and administrative data in the County's possession which the County may lawfully release including, but not limited to Contract specifications, drawings, correspondence, and other information specified and required by the Contractor and relating to its work under any Contract. The County reserves its rights of ownership to all material given to the Contractor by the County and to all background information documents, and computer software and documentation developed by the Contractor in performing any Contract.

36. DOCUMENTS: All documents, including but not limited to data compilations, drawings, reports and other material, whether in hard copy or electronic format, prepared, developed or furnished by the Contractor pursuant to any Contract shall be the sole property of the County. At the direction of the County, the Contractor shall have the right to make copies of the documents produced available to other parties. The County shall be entitled to delivery of possession of all documents, upon payment in accordance with the terms of any Contract for the service incurred to produce such documents.

37. CONFIDENTIALITY: Contractor shall not publish, copyright or otherwise disclose or permit to be disclosed or published, the results of any work performed pursuant to this contract, or any particulars thereof, including forms or other materials developed for the County in connection with the performance by Contractor of its services hereunder, without prior written approval of the County. Contractor, cognizant of the sensitive nature of much of the data supplied by the County, shall not disclose any information (other than information which is readily available from sources available to the general public) obtained by it in the course of providing services hereunder without the prior written approval of the County, unless disclosure of such information by it is required by law, rule or regulation or the valid order of a court or administrative agency.

38. INDEPENDENT CONTRACTOR: The Contractor and any agents, or employees of the Contractor, in the performance of any Contract shall act as an independent contractor and not as officers, employees or agents of the County.

39. INSURANCE: The Contractor agrees that, during the period of time it renders services to the County pursuant to any Contract, it shall carry (and provide the County with evidence of coverage) the following minimum amounts of insurance:

Automobile	\$500,000	Liability Medical Payment Comprehensive Collision
Public Liability	\$1,000,000	
Professional Liability	\$1,000,000	
Excess Liability	\$2,000,000	Aggregate Over Above Policy Limits (Excluding Professional Liability)
Worker's Compensation	Amount required by Virginia law	

The Contract may specifically require the Contractor to carry higher minimum amounts of insurance.

In addition, the Contractor shall require, and shall include in every subcontract, that any subcontractor providing any goods or services related to such Contract obtain, and continue to maintain for the duration of the work, workers' compensation coverage in the amount required by Virginia law.

40. KEY PERSONNEL: For the duration of any Contract, the Contractor shall make no substitutions of key personnel unless the substitution is necessitated by illness, death, or termination of employment, or as expressly approved by the County. The Contractor

shall notify the County within five (5) calendar days after the occurrence of any of these events and provide the information required by the paragraph below.

The Contractor shall provide a detailed explanation of the circumstances necessitating any proposed substitution, complete resumes for the proposed substitute, and any additional information requested by the County. The proposed substitute should have comparable qualifications to those of the person being replaced. The County will notify the Contractor within fifteen (15) calendar days after receipt of all required information of its approval or disapproval of the proposed substitution.

- 41. SEVERABILITY:** If any term, covenant or provision of these General Conditions or any Contract shall be held to be invalid, illegal or unenforceable in any respect, these General Conditions and any Contract shall remain in effect and be construed without regard to such provision.
- 42. TITLES:** The titles and section headings herein and in any Contract are inserted solely for convenience and are not to be construed as a limitation on the scope of the provisions to which they refer.
- 43. ATTORNEYS' FEES:** In the event of a dispute between the County and Contractor under any Contract which cannot be amicably resolved, in addition to all other remedies, the party substantially prevailing in any litigation shall be entitled to recover its reasonable expenses, including, but not limited to, reasonable attorneys' fees.
- 44. NO WAIVER:** Neither any payment for, nor acceptance of, the whole or any part of the services by the County, nor any extension of time, shall operate as a waiver of any provision of any Contract, nor of any power herein reserved to the County, or any right to damages herein provided, nor shall any waiver of any breach of any Contract be held to be a waiver of any other or subsequent breach. Failure of the County to require compliance with any term or condition of any Contract shall not be deemed a waiver of such term or condition or a waiver of the subsequent enforcement thereof.
- 45. NO FINANCE CHARGES:** No finance charges shall be paid by the County.
- 46. ANTITRUST:** By entering into a Contract, the Contractor conveys, sells, assigns, and transfers to the County all rights, title and interest in and to all causes of the action it may now have or hereafter acquire under the antitrust law of the United States or the State, relating to the particular Goods or Services purchased or acquired by the County under said Contract. Consistent and continued tie bidding could cause rejection of Bids by the County and/or investigation for antitrust violations.
- 47. PAYMENT:** Pursuant to Virginia Code § 2.2-4352, unless more time is provided in the Solicitation or Contract, payment will be made forty-five (45) days after receipt by the County of a proper invoice, or forty-five (45) days after receipt of all Goods or acceptance of work, whichever is later. The County reserves the right to withhold any or all payments or portions thereof for Contractor's failure to perform in accordance with the

provision of the Contract or any modifications thereto. Within twenty (20) days of receipt of proper invoice or of goods or services, the County shall notify the Contractor if any defect or impropriety that would prevent payment by the payment date. The following provisions apply to such payments:

- a. Invoices for items/Services ordered, delivered/performed and accepted shall be submitted by the Contractor in duplicate directly to the payment address shown on the purchase order, Solicitation or Contract, as applicable. All invoices shall show the Contract number, purchase order number, or Solicitation number, as applicable, and as required under Virginia Code § 2.2-4354, either the individual Contractor's social security number or the Contractor's federal employer identification number, whichever is applicable.
- b. Any payment terms requiring payment in less than forty-five (45) days will be regarded as requiring payment forty-five (45) days after receipt of proper invoice or receipt of all Goods or acceptance of work, whichever occurs later. Notwithstanding the foregoing, offers of discounts for payment in less than forty-five (45) days are valid and enforceable.
- c. Pursuant to Virginia Code § 2.2-4353, the date any payment shall be deemed the date of postmark in all cases where payment is made by mail.
- d. The County's fiscal year is July 1 to June 30. Contractors are advised to submit invoices, especially for Goods and/or Services provided in the month of June, for the entire month (i.e. June 1 - June 30), so that expenses are recognized in the appropriate fiscal year.
- e. Any payment made by the Contractor to the County shall only be made in U.S. Dollars. If payment is received in foreign currency the County may, in its sole discretion, reject such payment and require immediate compensation in U.S. Dollars.

48. SUBCONTRACTORS: Pursuant to Virginia Code § 2.2-4354, in the event that any subcontractors are used by Contractor in connection with the work, Contractor shall:

- a. Within seven (7) days after receipt of amounts paid to the Contractor for work performed by a subcontractor, either:
 - i. Pay the subcontractor for the proportionate share of the total payment received attributable to the work performed by the subcontractor under any Contract; or
 - ii. Notify the County and subcontractor, in writing, of his intention to withhold all or a part of the subcontractor's payment with the reason for nonpayment.

- b. Contractor shall require each subcontractor to provide either (i) for an individual, their social security numbers, or (ii) for proprietorships, partnerships, and corporations to provide their federal employer identification numbers.
- c. The Contractor shall pay interest to any subcontractor on all amounts owed by the Contractor that remain unpaid after seven days following receipt by the Contractor of payment from the County for work performed by the subcontractor under any Contract, except for amounts withheld as allowed in subdivision (a)(II) above. Unless otherwise provided under the terms of any Contract, interest shall accrue at the rate of one percent (1%) per month.
- d. The Contractor shall include in each of its subcontracts under any Contract a provision requiring each subcontractor to include or otherwise be subject to the above payment and interest requirements (a), (b) and (c) with respect to each lower tier subcontractor.
- e. The Contractor's obligation to pay an interest charge to a subcontractor pursuant to the payment clause in this Section 48 shall not be construed to be an obligation of the County. No Contract modification may be made for the purpose of providing reimbursement for such interest charge. No cost reimbursement claim may include any amount for reimbursement for such interest charge.

49. RETAINAGE ON CONSTRUCTION CONTRACTS: Pursuant to Virginia Code 2§ 2.2-4333, if a Contract for construction provides for progress payments in installments based upon an estimated percentage of completion, then the contractor shall be paid at least ninety-five percent (95%) of the earned sum when payment is due, with no more than five percent (5%) being retained to ensure faithful performance of the contract. All amounts withheld may be included in the final payment. Any subcontract related to work on a Contract that provides for similar progress payments shall be subject to the provisions above and the Contractor agrees to include such provisions in every subcontract.

50. SUCCESSORS AND ASSIGNS: The County and the Contractor bind themselves and their respective successors and assigns to any Contract. The foregoing notwithstanding, the Contractor shall not assign, sublet or transfer its interest in any Contract without the prior written consent of the County, which may be granted or withheld in the County's sole discretion. Nothing hereinafter mentioned shall be construed as creating any personal liability on the part of any officer, agent or employee of the County, nor shall it be construed as giving any benefits hereunder to anyone other than the County and the Contractor.

51. DEFAULT: Failure of a Contractor to deliver Goods or Services in accordance with Contract terms and conditions and/or within the time specified, or within reasonable time as interpreted by the County in its sole discretion, or failure to make replacements/corrections of rejected articles/services when so requested, immediately or as directed by the County, or failure of the Contractor to act in accordance with the Contract in any material respect, as reasonably determined by the County, shall constitute

a “default” by the Contractor and shall further authority for the County to purchase in the open market articles/services of comparable grade/quality to replace the services, articles rejected, and/or not delivered. On all such purchases, the Contractor shall reimburse the County, within a reasonable time specified by the County, for any expense incurred in excess of Contract prices including, but not limited to, any purchase and administrative costs. Such purchases shall be deducted from the Contract quantities, if applicable. Should public necessity demand it, the County reserves the right to use or consume articles delivered or services performed which are substandard in quality, subject to an adjustment in price to be determined by the County. In case of any default, the County, after due oral or written notice if required in accordance with the Contract, may terminate the Contract at its option in its sole discretion effective immediately. These remedies shall be in addition to any other remedies which the County may have, including but not limited to, any remedies at law, under the Contract or in equity.

Notwithstanding the foregoing, the Contractor shall not be liable for damages for delay in shipment or failure to deliver when such delay or failure is the result of fire, flood, strike, act of God, act of Government, act of an alien enemy or by any other circumstances which, in the County's opinion, are beyond the control of the Contractor. Under such circumstances, however, the County may, at its sole discretion, terminate or cancel the Contract effective immediately.

52. NON-DISCRIMINATION ASSURANCES: The Contractor shall conform to the provisions of the Federal Civil Rights Act of 1964, as amended, as well as the Virginia Fair Employment Act of 1975, as amended, where applicable, and § 2.2-4311 of the Virginia Procurement Act:

- a. During the performance of any Contract, the Contractor agrees as follows: the Contractor will not discriminate against any employee or applicant for employment because of race, religion, color, sex, national origin, age, disability, or other basis prohibited by state law relating to discrimination in employment, except where there is a bona fide occupational qualification reasonably necessary to the normal operation of the Contractor. The Contractor agrees to post in conspicuous places, available to employees and applicants for employment, notices setting forth the provisions of this nondiscrimination clause. The Contractor, in all Solicitations or advertisements for employees placed by or on behalf of the Contractor, will state that such Contractor is an equal opportunity employer. Notices, advertisements and Solicitations placed in accordance with federal law, rule or regulation shall be deemed sufficient for the purpose of meeting the requirements of this Section 52.
- b. The Contractor shall include the provisions of paragraph (a) above in every subcontract or purchase over \$10,000.00 so that the provisions will be binding upon each subcontractor or Vendor.

53. MODIFICATION:

- a. Pursuant to Virginia Code § 2.2-4309, these General Conditions and any Contract entered into by the County and any Contractor shall not be subject to change, modification, or discharge except by written instrument signed by the County and Contractor, but no fixed-price contract may be increased by more than twenty-five percent (25%) of the amount of the contract or \$50,000, whichever is greater, without the advance written approval of the County's Board. In no event may the amount of any contract, without adequate consideration, be increased for any purpose, including, but not limited to, relief of an offeror from the consequences of an error in its bid or offer.
- b. The County may, but is not obligated to, extend the term of an existing contract for services to allow completion of any work undertaken but not completed during the original term of the contract.
- c. Nothing in this Section 53 shall prevent the County from placing greater restrictions on contract modifications.

54. INDEMNIFICATION: Contractor agrees to indemnify, keep and save harmless the County, its officers, agents, officials, employees and volunteers against any and all claims, claims of injuries, death, damage to property, patent claims, suits, liabilities, judgments, losses, costs and expenses, including but not limited to costs of investigation, all reasonable attorneys' fees (whether or not litigation results), and the cost of any appeal, occurring or arising in connection with the Contractor's, its agents', subcontractors', employees', or volunteers' negligence or wrongful acts or omissions in connection with its performance of any Contract. The Contractor shall, at his or her own expense, appear, defend and pay all charges of attorneys and all costs and other expenses arising therefrom or incurred in connection therewith; and if any judgment shall be rendered against the County in any such action, the Contractor shall, at his or her own expenses, satisfy and discharge the same. Contractor expressly understands and agrees that any performance bond or insurance protection required by any Contract, or otherwise provided by the Contractor, shall in no way limit the responsibility to indemnify, keep and save harmless and defend the County as herein provided. Nothing contained in this Solicitation or the Contract shall be deemed to be a waiver of the County's sovereign immunity.

55. DRUG-FREE WORKPLACE: Pursuant to Virginia Code § 2.2-4312, in every Contract over \$10,000.00 the following provisions apply: During the performance of any Contract, the Contractor agrees to (i) provide a drug-free workplace for the Contractor's employees; (ii) post in conspicuous places, available to employees and applicants for employment, a Statement notifying employees that the unlawful manufacture, sale, distribution, dispensation, possession, or use of a controlled substance or marijuana is prohibited in the Contractor's workplace and specifying the actions that will be taken against employees for violations of such prohibition; (iii) state in all Solicitations or advertisements for employees placed by or on behalf of the Contractor that the Contractor maintains a drug-free workplace; and (iv) include the provisions of the

foregoing clauses in every subcontract or purchase order of over \$10,000, so that the provisions will be binding upon each subcontractor or vendor.

For the purposes of this Section, “*drug-free workplace*” means a site for the performance of work done in connection with a specific Contract awarded to a Contractor in accordance with this the VPPA and the County’s Procurement Procedures, the employees of whom are prohibited from engaging in the unlawful manufacture, sale, distribution, dispensation, possession or use of any controlled substance or marijuana during the performance of the Contract.

56. TERMINATION: Contracts will remain in force for full periods specified and/or until all articles ordered before date of termination shall have been satisfactorily delivered and accepted and thereafter until all requirements and conditions shall have been met, unless:

- a. Terminated prior to expiration date by satisfactory deliveries of entire Contract requirements;
- b. Terminated by the County upon thirty (30) days written notice to the Contractor at the County’s convenience in the County’s sole discretion (“termination for convenience”), unless a termination for convenience is specifically and expressly prohibited by the Contract. Any Contract cancellation notice shall not relieve the Contractor of the obligation to deliver and/or perform on all outstanding orders issued prior to the effective date of the termination;
- c. Terminated by the County for cause, default or negligence on the part of the Contractor. However, pursuant to Section 51 of these General Conditions, the County may hold the Contractor responsible for any resulting additional purchase and administrative costs. There is no advance notice requirement in the event of Termination for Cause and termination is effective immediately upon notice to Contractor of the termination for cause;
- d. Extended upon written authorization of County and accepted by Contractor, to permit ordering of unordered balances or additional quantities at Contract prices and in accordance with Contract terms.

57. APPROPRIATIONS: Notwithstanding any other provision of any Contract, the payment of the County's obligations under any Contract shall be subject to annual appropriations by the Board of Supervisors of the County in each fiscal year of monies sufficient to satisfy the same.

58. REFERENCES TO VIRGINIA LAW: Any reference in these General Conditions to the Code of Virginia or other relevant Federal, State or local law is incorporated in whole herein by reference as in effect at the time of the Solicitation or Contract as such statutory provisions may be amended or replaced by any statute dealing with the same or similar subject matter.

59. COOPERATIVE PROCUREMENT: Except as prohibited by the current Code of Virginia, all resultant Contracts will be extended to other Public Bodies of the Commonwealth of Virginia, to permit their ordering of Goods, supplies and/or Services at the prices and terms of the resulting Contract (“cooperative procurement”). By submitting any Bid or entering into any Contract with the County a Bidder/Contractor expressly authorizes cooperative procurement under Virginia Code § 2.2-4304 to the full extent permitted by law. If any other public body decides to use any Contract, the Contractor must deal directly with that public body concerning all matters relating thereto, including but not limited to, the placement or orders, issuance of the purchase order, contractual disputes, invoicing and payment. The County acts only as the “Contracting Agent” for these public bodies. Any resulting contract with other public bodies shall be governed by the laws of that specific entity. It is the Contractor’s responsibility to notify the public bodies of the availability of the Contract. Fluvanna County shall not be held liable for any direct or indirect costs, damages or other claim of any kind incurred by another public body or any Contractor as a result of any cooperative procurement.

60. AUDIT: The Contractor hereby agrees to retain all books, records and other documents relative to any Contract for five (5) years after final payment, or until audited by the County, whichever is sooner. The County, its authorized agents, and/or County auditors shall have full access to and right to examine any of said materials during said period.

61. GUARANTIES AND WARRANTIES: All guarantees, representations and warranties required shall be furnished by the Contractor and shall be delivered to the Purchasing Agent before final payment on any Contract is made. In addition to any guarantees, representations and warranties required under the Contract, the Contractor agrees to:

- a. Save the County, its agents and employees harmless from liability of any nature or kind for the use of any copyrighted or un-copyrighted composition; secret process, patented or unpatented; invention; article or appliance furnished or used in the performance of a Contract for which the Contractor is not the patentee, assignee, licensee or owner;
- b. Protect the County against latent defective material or workmanship and to repair or replace any damages or marring occasioned in transit or delivery;
- c. Furnish adequate protection against damage to all work and to repair damages of any kind to the building or equipment, to the Contractor’s own work or to the work of other contractors, for which the Contractor’s workers are responsible;
- d. Pay for all permits, licenses and fees and give all notices and comply with all laws, ordinances, rules and regulations of the County; and
- e. Protect the County from loss or damage to County owned property while it is in the custody of the Contractor;

- f. At minimum supply all Goods or Services with the manufacturer's standard warranty, if applicable; and
- g. For any Contract involving Services of any nature, the Contractor further agrees to:
 - i. Enter upon the performance of Services with all due diligence and dispatch, assiduously press to its complete performance, and exercise therein the highest degree of skill and competence;
 - ii. Allow Services to be inspected or reviewed by an employee of the County at any reasonable time and place selected by the County;
 - iii. Acknowledges that the County shall be under no obligation to compensate Contractor for any Services not rendered in strict conformity with the Contract; and
 - iv. Stipulates that the presence of a County Inspector shall not lessen the obligation of the Contractor for performance in accordance with the Contract requirements, or be deemed a defense on the part of the Contractor for infraction thereof. The Inspector is not authorized to revoke, alter, enlarge, relax, or release any of the requirements of any Contract. Any omission or failure on the part of the Inspector to disapprove or reject any work or material shall not be construed to be an acceptance of any such defective work or material.

62. PRICE REDUCTIONS: If at any time after the date of the Bid/Contract the Contractor makes a general price reduction in the comparable price of any material covered by the Contract to customers generally, an equivalent price reduction based on similar quantities and/or considerations shall apply to any Contract for the duration of the Contract period (or until the price is further reduced). Such price reduction shall be effective at the same time and in the same manner as the reduction in the price to customers generally. For purpose of this provision, a "general price reduction" shall mean any horizontal reduction in the price of an article or service offered (1) to Contractor's customers generally, or (2) in the Contractor's price schedule for the class of customers, i.e., wholesalers, jobbers, retailers, etc., which was used as the basis for bidding on this Solicitation. An occasional sale at a lower price, or sale of distressed merchandise at a lower price, would not be considered a "general price reduction" under this provision. The Contractor shall submit his or her invoice at such reduced prices indicating on the invoice that the reduction is pursuant to the "Price Reduction" provision of the Contract documents. The Contractor in addition will within ten (10) days of any general price reduction notify the County of such reduction by letter. **FAILURE TO DO SO IS A DEFAULT UNDER THE CONTRACT AND MAY RESULT IN TERMINATION OF THE CONTRACT IN THE COUNTY'S DISCRETION.** The Contractor, if requested, shall furnish, within ten (10) days after the end of the Contract period, a statement certifying either (1) that no general price reduction, as defined above, was made after the date of the Bid or Contract, or (2) if any such general price reductions were made, that as provided above, they were reported to the County within ten (10) days and the County was billed at the reduced prices. Where one or more such general price reductions were made, the statement furnished by

the Contractor shall include with respect to each price reduction (1) the date when notice of any such reduction was issued, (2) the effective date of the reduction, and (3) the date when the County was notified of any such reduction.

63. COMPLIANCE WITH IMMIGRATION LAW: Pursuant to Virginia Code § 2.2-4311.1, in every Contract the following provision applies: the Contractor does not, and shall not during the performance of the Contract, knowingly employ an unauthorized alien as defined in the federal Immigration Reform and Control Act of 1986.

64. VIRGINIA STATE CORPORATION COMMISSION: Pursuant to Virginia Code § 2.2-4311.2, Any Bidder or Contractor organized as a stock or non-stock corporation, limited liability company, business trust, or limited partnership or registered as a registered limited liability partnership shall be authorized to transact business in the Commonwealth as a domestic or foreign business entity if so required by Title 13.1 or Title 50 of the Code of Virginia, or as otherwise required by law, at the time of the Bid, Proposal or any response to Solicitation and during the term of the Contract and any Contract renewal. The Contractor shall not allow its existence to lapse or its certificate of authority or registration to transact business in the Commonwealth, if so required, to be revoked or cancelled at any time during the term or any renewal of the Contract. If the Contractor fails to remain in compliance with the provisions of this Section 64, the Contract may become void at the option of the County.

65. CLAIMS PROCEDURE:

- a. The procedure for consideration by the County of contractual claims for any Contract shall be that set forth in Virginia Code § 15.2-1243, *et seq.*
- b. In addition, pursuant to Virginia Code § 2.2-4364, contractual claims, whether for money or other relief, shall be submitted in writing to the County Administrator no later than sixty (60) days after final payment; however, written notice of the Contractor's intention to file such claim shall have been given at the time of the occurrence or beginning of the work upon which the claim is based. Nothing herein shall preclude a Contract from requiring submission of an invoice for final payment within a certain time after completion and acceptance of the work or acceptance of the Goods. Pendency of claims shall not delay payment of amount agreed due in the final payment.
- c. No written decision denying a claim or addressing issues related to the claim shall be considered a denial of the claim unless the written decision is signed by the Board or the County Administrator. The contractor may not institute legal action prior to receipt of the final written decision on the claim unless the County fails to render a decision within ninety (90) days of submission of the claim. Failure of the County to render a decision within ninety (90) days shall not result in the contractor being awarded the relief claimed or in any other relief or penalty. The sole remedy for the County's failure to render a decision within 90 days shall be the contractor's right to institute immediate legal action.

- d. A Contractor may not institute legal action, prior to receipt of the County's decision on the claim, unless the County fails to render such decision within the time specified by law. A failure by the County to render a decision within the time provided by law shall be deemed a final decision denying the claim by the County.
- e. The decision of the Board or the County Administrator shall be final and conclusive unless the Contractor appeals within six (6) months of the date of the final written decision by instituting legal action as provided in Virginia Code § 2.2-4364.
- f. No administrative appeals procedure pursuant to Virginia Code § 2.2-4365 has been adopted for contractual claims by the County.
- g. Nothing herein shall be construed to prevent the County from instituting legal action against any Contractor or Bidder.

66. NOTICES: All written notices required or permitted under any Solicitation, Bid or Contract shall be deemed sufficient if delivered in person to the County Purchasing Agent or Bidder/Contractor, as applicable, or sent by first class mail to the County or Bidder/Contractor at the addresses set forth in the Solicitation, Bid or Contract or at such other address as a party may designate from time to time by notice given in accordance with the terms of this Section 66; except that where a Solicitation, Bid or Contract expressly requires notice to a specific individual or at a specific location, such shall control. Such notices are deemed received when actually delivered to the party or its representative or agent if hand delivered, or one (1) business day after deposited into the United States mail, if mailed.

DELIVERY

67. SHIPPING INSTRUCTIONS-CONSIGNMENT: Unless otherwise specified in the Solicitation or Contract, as applicable, each case, crate, barrel, package, etc., delivered under the Contract must be plainly stenciled or securely tagged, stating the Contractor's name, purchase order number, and delivery address as indicated in the order. Where shipping containers are to be used, each container must be marked with the purchase order number, name of the Contractor, the name of the item, the item number, and the quantity contained therein. Deliveries must be made within the hours of 8:00 a.m. – 3:00 p.m. Deliveries at any other time will not be accepted unless specific arrangements have been previously made with the designated individual at the delivery point. No deliveries will be accepted on Saturdays, Sundays and holidays unless previous arrangements have been made. It shall be the responsibility of the Contractor to insure compliance with these instructions for items that are drop-shipped.

68. RESPONSIBILITY FOR SUPPLIES TENDERED: The Contractor shall be responsible for the materials or supplies covered by the Contract until they are delivered

at the designated point. The Contractor shall additionally bear all risk on rejected materials or supplies after notice of rejection is tendered by the County. Rejected materials or supplies must be removed by and at the expense of the Contractor promptly after notification of rejection, unless public health and safety require immediate destruction or other disposal of rejected delivery. If rejected materials are not removed by the Contractor within ten (10) days after date of notification, the County may return the rejected materials or supplies to the Contractor at the Contractor's risk and expense or dispose of them as abandoned property.

69. INSPECTIONS: The County reserves the right to conduct any test/inspection it may deem advisable to assure supplies and Services conform to the specification in the Solicitation, Bid or Contract, as applicable. Inspection and acceptance of materials or supplies will be made after delivery at destinations herein specified unless otherwise stated. Unless otherwise specified in the Contract, if inspection is made after delivery at the destination specified, the County will bear the expense of inspection except for the value of samples used in case of rejection. Final inspection shall be conclusive except in regard to latent defects, fraud or such gross mistakes as to amount to fraud. Final inspection and acceptance or rejection of the materials or supplies will be made as promptly as practicable, but failure to inspect and accept or reject materials or supplies shall not impose liability on the County for such materials or supplies as are not in accordance with the specifications.

70. COMPLIANCE: Delivery must be made as ordered and in accordance with the Solicitation, Bid or Contract, as applicable, or as directed by the County when not in conflict with the Bid/Contract. The decision as to reasonable compliance with delivery terms shall be final. Burden of proof of delay in receipt of Goods by the purchaser shall rest with the Contractor. Any request for extension of time of delivery from that specified must be approved by the County, such extension applying only to the particular item or shipment affected. Unless otherwise specified in the Contract, should the Contractor be unreasonably delayed by the County, there shall be added to the time of completion a time equal to the period of such delay caused by the County. However, the Contractor shall not be entitled to claim damages or extra compensation for such delay or suspension. These conditions may vary for construction Contracts.

71. POINT OF DESTINATION: All materials shipped to the County must be shipped F.O.B. DESTINATION unless otherwise stated specifically in the Solicitation, Bid or Contract, as applicable. The materials must be delivered to the "Ship To" address indicated on the purchase order or Solicitation, as applicable.

72. REPLACEMENT: Materials or components that have been rejected by the County, in accordance with the terms of the Contract, shall be replaced by the Contractor at no cost to the County.

73. DAMAGES: Any and all damages to property of the "County" that is the direct result of the Contractor, the employees of the Contractor and/or its subcontractors, agents, licensees, successors, or assigns, shall be the sole responsibility of the Contractor. The

property shall be repaired to its last known condition prior to the damages and/or replaced at no cost to the County. The County shall approve any and all repairs/replacements prior to acceptance of the repairs/replacement.

74. PACKING SLIPS OR DELIVERY TICKETS: All shipments shall be accompanied by Packing Slips or Delivery Tickets and shall contain the following information for each item delivered:

- a. Purchase Order Number;
- b. Name of Article and Stock Number;
- c. Quantity Ordered;
- d. Quantity Shipped;
- e. Quantity Back Ordered; and
- f. The Name of the Contractor.

Contractors are cautioned that failure to comply with these conditions shall be considered sufficient reason for refusal to accept the Goods.

75. ADDITIONAL CHARGES: No delivery charges of any kind shall be added to any invoice; except that (i) if Goods are expressly bought F.O.B. "shipping point" under the Contract and the Contractor prepays transportation, then delivery charges shall be added to invoices; and (ii) if express delivery is authorized and substituted by the County on orders for the method specified in the Contract, then the difference between freight or mail and express charges may be added to invoice.

76. METHOD AND CONTAINERS: Unless otherwise specified, Goods shall be delivered in commercial packages in standard commercial containers, so constructed as to ensure acceptance by common or other carrier for safe transportation to the point of delivery. Containers become the property of the County unless otherwise specified by bidder.