



# FLUVANNA COUNTY PLANNING COMMISSION

## REGULAR MEETING AGENDA

Carysbrook Performing Arts Center  
8880 James Madison Highway  
Fork Union, VA 23055

Tuesday, March 8, 2022

Regular Meeting at 7:00 pm

---

### TAB AGENDA ITEMS

---

**No Work Session at 6:00 pm**

---

### REGULAR MEETING

---

**1 – CALL TO ORDER, PLEDGE OF ALLEGIANCE AND FOLLOWED BY A MOMENT OF SILENCE**

---

**2 – DIRECTOR’S REPORT – Douglas Miles, AICP, CZA, Community Development Director**

---

**3 – PUBLIC COMMENTS #1 (5 minutes per speaker)**

---

**4 – MINUTES: Review and Approval of Draft Minutes from February 8, 2022**

---

**5 – PUBLIC HEARINGS: None**

---

**6 – PRESENTATIONS: None**

---

**7 – SITE DEVELOPMENT PLANS: None**

---

**8 – SUBDIVISIONS:**

**SUB 22:02 Village Gardens** – A Sketch Plan request for a rural cluster major subdivision with respect to 116.8 acres of Tax Maps 8 Section A Parcel 18A and 17 Section 9 Parcels 1 and 2. The applicant is proposing 48 cluster lots with one residual parcel of 93.8 acres designated as open space that permits one house. The subject properties are located along Garden Lane (SR 636) with access to Thomas Jefferson Parkway (SR 53) to serve the rural cluster development.

---

**9 – UNFINISHED BUSINESS: None**

---

**10 – NEW BUSINESS:**

**Appointment of Resident Advisory Groups:** Zion Crossroads Stakeholders Group (3 residents); Rural Crossroads & Rural Preservation Advisory Group (6 residents) and Historic Preservation Advisory Group (3 residents) to be selected from Fluvanna County residents who have applied to provide input into the 2040 Comprehensive Plan in Spring 2022.

---

**11 – PUBLIC COMMENTS #2 (5 minutes per speaker)**

---

**12 – ADJOURNMENT**

---

*Douglas Miles*

---

Community Development Director Review

*Fluvanna County...The heart of Virginia and your gateway to the future!*

*For the Hearing-Impaired – Listening devices are available upon request. TTY access number is 711 to make arrangements.  
For Persons with Disabilities – If you have special needs, please contact the County Administrator's Office at 434.591.1910.*

\*\*\*\*\*

## PLEDGE OF ALLEGIANCE

I pledge allegiance to the flag  
of the United States of America  
and to the Republic for which it stands,  
one nation, under God, indivisible,  
with liberty and justice for all.

\*\*\*\*\*

## ORDER

1. It shall be the duty of the Chair to maintain order and decorum at meetings. The Chair shall speak to points of order in preference to all other members.
2. In maintaining decorum and propriety of conduct, the Chair shall not be challenged and no debate shall be allowed until after the Chair declares that order has been restored. In the event the Commission wishes to debate the matter of the disorder or the bringing of order; the regular business may be suspended by vote of the Commission to discuss the matter.
3. No member or citizen shall be allowed to use abusive language, excessive noise, or in any way incite persons to use such tactics. The Chair shall be the judge of such breaches, however, the Commission may vote to overrule both.
4. When a person engages in such breaches, the Chair shall order the person's removal from the building, or may order the person to stand silent, or may, if necessary, order the person removed from the County property.

## PUBLIC HEARING RULES OF PROCEDURE

1. PURPOSE
  - The purpose of a public hearing is to receive testimony from the public on certain resolutions, ordinances or amendments prior to taking action.
  - A hearing is not a dialogue or debate. Its express purpose is to receive additional facts, comments and opinion on subject items.
2. SPEAKERS
  - Speakers should approach the lectern so they may be visible and audible to the Commission.
  - Each speaker should clearly state his/her name and address.
  - All comments should be directed to the Commission.
  - All questions should be directed to the Chair. Members of the Commission are not expected to respond to questions, and response to questions shall be made at the Chair's discretion.
  - Speakers are encouraged to contact staff regarding unresolved concerns or to receive additional information.
  - Speakers with questions are encouraged to call County staff prior to the public hearing.
  - Speakers should be brief and avoid repetition of previously presented comments.
3. ACTION
  - At the conclusion of the public hearing on each item, the Chair will close the public hearing.
  - The Commission will proceed with its deliberation and will act on or formally postpone action on such item prior to proceeding to other agenda items.
  - Further public comment after the public hearing has been closed generally will not be permitted.

*Fluvanna County...The heart of Virginia and your gateway to the future!*

*For the Hearing-Impaired – Listening devices are available upon request. TTY access number is 711 to make arrangements.  
For Persons with Disabilities – If you have special needs, please contact the County Administrator's Office at 434.591.1910.*

**FLUVANNA COUNTY PLANNING COMMISSION  
REGULAR MEETING MINUTES**

**Carysbrook Performing Arts Center  
8880 James Madison Highway  
Fork Union, VA 23055**

**February 8, 2022  
Regular Meeting 7:00 pm**

**MEMBERS PRESENT:**

Barry Bibb, Chair  
Gequetta “G” Murray-Key, Vice Chair  
Lewis Johnson, Commissioner  
Ed Zimmer, Commissioner  
Howard Lagomarsino, Commissioner  
Patricia Eager, Board of Supervisors Representative

**ABSENT:**

**STAFF PRESENT:**

Eric Dahl, County Administrator  
Fred Payne, County Attorney  
Douglas Miles, Community Development Director  
Jason Overstreet, Senior Planner  
Jon-Mikel Whalen, Planner / GIS Technician  
Valencia Porter, Administrative Programs Specialist

**1. CALL TO ORDER, THE PLEDGE OF ALLEGIANCE AND A MOMENT OF SILENCE:**

At 7:00 pm, Chair Bibb, called the February 8, 2022 Regular Meeting to Order, led in the Pledge of Allegiance and then he conducted a Moment of Silence.

**2. DIRECTOR’S REPORT – Douglas Miles, AICP, CZA, Community Development Director**

**February 10th Technical Review Committee Meeting:**

250 and Edgcomb Road: New 52,500 square foot Industrial Building: Phase 1 Site was rezoned to I-1 Office & Warehouse land uses in July 2021

Route 53 Self Storage – Electrical Contractor and Realty Offices: A Rezoning and SUP for 1,000 square feet of Office space and 60,400 square feet for self-storage units located behind offices

Agricultural Enterprise SUP – Meadery: existing business to create 1,200 square feet for a meadery with retail sales and a tasting room with a patio.

**County Residents selected for Advisory Groups:**

Fluvanna County Staff has received all of the Applications to be considered for serving on proposed Resident Advisory Groups to perform analysis and work on the 2040 Comp Plan.

Planning Staff has compiled all of them and has provided them to the Planning Commissioners to take tonight and to review them for consideration for Zion Crossroads, Rural Preservation and Historic Preservation groups and will make the selections on March 8, 2022 for advisory groups.

**County Residents selected for Advisory Groups**

Rural Crossroads Areas (RCA) and Rural Preservation Group: select up to 6 County residents  
Zion Crossroads Gateway Plan: select 3 County Residents to be added to the TJPDC meetings with planning and technical backgrounds.

Historic Preservation Group: select 3 County Residents to assist the Historical Society with both architect and historian backgrounds.

**Planning Commissioner Questions:**

**Vice Chair Murray-Key:** Asked will the Open House events be available for live streaming?

**Mr. Payne:** Stated that the structure of the Advisory Groups, they have been referred to as subcommittees and they are not subcommittees. That term has an established meaning, and this is not what they are intended to be. A subcommittee is an integral part of the legislative process and these groups are really intended to be a resource for the Planning Commission and the Board of Supervisors. That is why they are called resident advisory groups because that is

what they will do is they can give their thoughts on issues related to the plan. They do not get a vote they do not have any formal status. This is an opportunity for you all to try to select people that have particular interests and skills in various areas of subject matters. Hopefully what these groups will do is they will tend to focus on the issue for you all and focus on the issues involved. I would expect it to be an informal grouping purely ad hoc and without any independent legal status. I say that because I do not want anybody to get the idea that this was in fact a committee of the Planning Commission which is of course a legally established governmental body such to the freedom of information act. These advisory groups are much less formal than that and people are entitled to express what they may think is big ideas little ideas and their own thoughts and to serve as a resource for you to complete the revised plan.

**Mr. Zimmer:** asked how are we going to advertise the Comprehensive Plan Open House events since they will be monthly, be located in the Fluvanna County Library, as a centralized location.

**Mr. Miles:** stated that we plan to use several of our current methods of notifying our County residents such as FAN Mail and County website notifications and we will have display boards.

**3. PUBLIC COMMENTS #1**

Chair Bibb opened up the Public Comments at 7:27 pm by giving each public speaker a limit of five (5) minutes to speak and asked that they state their name and their address for the record. With no one wishing to speak in person or online, Chair Bibb closed the first round of Public Comments at 7:28 pm.

**4. MINUTES:**

<b>MOTION:</b>	<b>To approve the minutes of the Planning Commission of January 11, 2022, as presented.</b>				
<b>MEMBER:</b>	Bibb	Johnson	Murray-Key	Lagomarsino	Zimmer
<b>ACTION:</b>		<b>Second</b>		<b>Motion</b>	
<b>VOTE:</b>	Yes	Yes	Yes	Yes	Yes
<b>RESULT:</b>	<b>5-0 Approved</b>				

**5. PUBLIC HEARINGS:**

None

**6. PRESENTATIONS:**

**Comprehensive Plan Presentation – Douglas Miles, AICP, CZA Community Development Director**

**You are either in a CPA or Out in the Rural Preservation Area**

On the 2015 Future Land Use Map you have three current options: in Community Planning Area (CPA) in a hybrid (confusing) Rural Residential Area or Out and in the Rural Preservation Area

Planning Staff is proposing to eliminate Rural Residential Areas and have Rural Preservation Areas cover the remainder of County except within the Community Planning Areas (CPAs)

**Fluvanna Staff has been Listening and Taking Notes:**

You want County Staff to support commercial areas that will provide for shopping, dining and medical facilities in our County along with our business owners within the community being supported to start and expand their business.

We are doing this with Small Business support; more to be done with office and industrial uses. You want the County Staff, VDH & VDOT and the community to work together on a need for Rural Clustering by following the Virginia State Code to retain it and to be enacted within our rural areas.

Rural Clusters should not be allowed in the CPAs; will be looked at in Comp Plan and be addressed within our Ordinances after Comp Plan adoption.

You want the County Staff, developers and the community to work together to enhance and to maintain the Rural Character of Fluvanna County:

Agricultural farming and Livestock management; access to wildlife areas or perpetual green space; will be addressed by Residential Advisory Group for both Rural Crossroads and Rural Preservation

**2040 Fluvanna County Comprehensive Plan:**

Our Plan currently calls for new development to occur in the Zion Crossroads CPA and the UDA for new office, commercial and industrial land uses.

Fork Union Commerce Park it is also planned for additional agribusiness and new technology uses for economic development and jobs in that area.

**Transportation:**

2018-2021 Thomas Jefferson PDC Regional Completed Plans:

2040 Rural Long Range Transportation Plan: 201 with Planned Roads and VDOT improvements set framework for better, long term development ahead of new growth to occur in the County.

**Available Housing:**

Regional Housing Partnership Affordability Plan – 2021 Fluvanna County has density & housing type choices to select from as we grow for current and future County residents, have to make it available to become Affordable Housing.

**Transportation / Housing / Future Land Use Decisions:**

Future Land use is where the Planning staff needs the MOST PUBLIC INPUT into the process and as VA allows for local Land Use decisions

Rural Crossroads Areas are another planning recommendation to enhance rural business areas while preserving the corner markets

**Spring 2022 Open House & Rural Preservation Group Schedule**

Day	Date	Time	Group Meets During Open House Staff Event	Location
THURS	MAR 10	4:00-6:00	Comp Plan Kickoff Open House	Library Mtg Rooms A & B
THURS	APR 14	4:00-6:00	Group 4:00-5:00 / Open House 4:00-6:00	Library Mtg Rooms A & B
THURS	MAY 12	4:00-6:00	Group 4:00-5:00 / Open House 4:00-6:00	Library Mtg Rooms A & B
THURS	JUN 9	4:00-6:00	Group 4:00-6:00 / Open House 4:00-6:00	Library Mtg Rooms A & B

**Summer & Fall Draft 2040 Comprehensive Plan Document Review**

Day	Date	Time	Planning Commission Work Session & Comments	Location
TUES	AUG 9	6:00-9:00	Commission Work Session & Public Comments	Carysbrook Center
TUES	SEPT 13	6:00-9:00	Commission Work Session & Public Comments	Carysbrook Center
TUES	OCT 11	6:00-9:00	Planning Commission – 2040 Comp Plan Review	Carysbrook Center
WEDS	NOV 16	5:00-9:00	Board of Supervisors – 2040 Comp Plan Review	Carysbrook Center

**7. SITE DEVELOPMENT PLANS:**

None

**8. SUBDIVISIONS:**

None

**9. UNFINISHED BUSINESS:**

None

**10. NEW BUSINESS:**

None

**11. PUBLIC COMMENTS #2:**

Chair Bibb opened up the Public Comments at 8:19 pm by giving each speaker a limit of five (5) minutes to speak and asked that they state their full name and property address for the record.

**Christine Jacobs** Thomas Jefferson Planning District Commission Executive Director and she just wanted to state that the staff here at the TJ PDC stands ready to support you all in any way that we can. In the review of your comprehensive plan and especially as it relates to any documents or any plans that we have created in the past couple of years. I wanted to share our support publicly and that to reach out to us as you need any planning assistance with your 2040 Plan.

With no one else coming forward wishing to speak in person or online, Chair Bibb closed the Public Comments period at 8:23 pm.

**12. ADJOURNMENT:**

Chair Bibb adjourned the Planning Commission meeting on February 8, 2022 at 8:23 pm.

Minutes were recorded by Valencia Porter, Administrative Programs Specialist.

---

**Barry A. Bibb, Chair**  
**Fluvanna County Planning Commission**

DRAFT

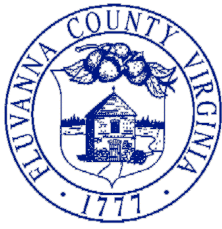

---

# COUNTY OF FLUVANNA

---

*"Responsive & Responsible Government"*

132 Main Street  
P.O. Box 540  
Palmyra, VA 22963  
(434) 591-1910  
Fax (434) 591-1911  
[www.fluvannacounty.org](http://www.fluvannacounty.org)

## PLANNING COMMISSION STAFF REPORT

**To:** Fluvanna County Planning Commission      **From:** Douglas Miles, AICP, CZA  
**Case:** SUB 22:02 Village Gardens Subdivision      **District:** Cunningham Election District  
**Date:** Tuesday, March 8, 2022 at 7:00 pm      **Site:** Carysbrook Performing Arts Center

**Requested Action:**      **SUB 22:02 Village Gardens** – A Sketch Plan request for a rural cluster major subdivision with respect to 116.8 acres of Tax Maps 8 Section A Parcel 18A and 17 Section 9 Parcels 1 and 2. The applicant is proposing 48 cluster lots with one residual parcel of 93.8 acres designated as open space that permits one house. The subject properties are located along Garden Lane (SR 636) with access to Thomas Jefferson Parkway (SR 53) to serve the rural cluster development. Note: This is not a scheduled Public Hearing.

**Existing Zoning:**      A-1, General Agricultural Zoning District, is known as Tax Map 8 Section A Parcel 18A and Tax Maps 17 Section 9 Parcels 1 and 2.

**Proposed Request:**      Rural Cluster Major Subdivision request

**Planning Area:**      Rivanna Community Planning Area that calls for residential uses.

**Adjacent Land Uses:**      Adjacent properties are zoned A-1 and R-4 and they either contain single-family dwellings or they are vacant or agricultural parcels.

### **Rural Cluster Subdivisions:**

The rural cluster development requirements are outlined in Section 22-4-10 in the A-1 Zoning District in the Zoning Ordinance. A Yield Plan and Sketch Plan are required to be submitted for review by the Planning Commission within the Subdivision Ordinance. A Yield Plan, it is used to determine the number of lots that could be developed on the subject property as a conventional subdivision, in accordance with all applicable regulations. A Sketch Plan is a conceptual plan of the proposed rural cluster subdivision and is used for the purpose of discussion and providing the subdivider with comments before investing in preparation of a preliminary plat in order to create and to complete a rural cluster major subdivision plat and site development plan for construction.

### **Yield Plan Analysis:**

The yield plan it was prepared based on what could be practicably developed on the property as a conventional major subdivision. In an A-1 Zoning District, the maximum residential density that

is allowed is one (1) dwelling unit per every two (2) acres. Based on the subject acreage alone 58 lots would be permitted; however, careful consideration must also be given to the area of land which would be occupied by roads and other areas not usable for building or individual sale such as steep slopes or flood plain areas as described in Section 19-4-5 in the Subdivision Ordinance.

As a result, the applicant shows forty-nine (49) lots on their yield plan which complies with this requirement and County staff has reviewed this yield plan based upon the subdivision and zoning ordinance requirements and it has been submitted to the Fluvanna County Planning Commission.

### **Sketch Plan Analysis:**

The revised Sketch Plan has been reviewed and we have confirmed the gross residential density of the development does not exceed one (1) dwelling unit per every two (2) acres as required by the A-1 Zoning District. The maximum density allowed is 58 dwelling units as shown on the yield plan. The applicant proposes forty-eight (48) residential lots plus one (1) dwelling in open space, which equates to a total of forty-nine (49) dwelling units and a gross density of 0.84 dwelling units per acre. A total of 93.8 acres is proposed to be retained in open space, which is 80% and that exceeds the minimum of 75% of the total acreage of the rural cluster development.

The proposed lots in this development will be fronting new public roads shown as Roads A, B & C on the revised Sketch Plan and they are all required to meet the R-4 residential zoning district setback requirements. The applicant has proposed two (2) entrances onto Garden Lane (SR 636) which has a posted 35 MPH speed limit to serve the proposed rural cluster major subdivision with Garden Lane providing direct access to Thomas Jefferson Parkway (SR 53) in this vicinity.

The revised Sketch Plan has been designed with consideration to the existing topography and soil suitability as to maximize the efficient use and utility of the land. The applicant has delineated areas with steep slopes that are greater than 20% as well as the required building setbacks being shown on all of the proposed rural cluster lots. They have proposed and designed SWM facilities to be located in the areas where the steep slopes are present to allow for better on-site retention.

### **Technical Review Committee Meeting:**

The Technical Review Committee (TRC) members met on February 24, 2022 with the applicant and engineering consultant to review the February 1, 2022 Village Gardens Rural Cluster Sketch Plan, as submitted by Timmons Group in Charlottesville, for the Sketch Plan review comments.

The applicant indicated that the proposed 48 lots within this development will be served by water and sanitary sewer utilities as provided by Aqua Virginia surrounding connections as the subject properties are located directly across Garden Lane from the Aqua Virginia complex. The Aqua Virginia State Engineer confirmed during this TRC meeting that they would supply both the water and sewer needs for the proposed forty-eight (48) lots with the open space parcel using a well and drainfield area for the review and approval by the VDH – Fluvanna Health Department.

The applicant along with their consultant revised the February 1, 2022 Sketch Plan and submitted a revised Sketch Plan dated February 28, 2022 making the following revisions to the sketch plan:



Added sidewalks on both sides of the proposed streets for VDOT sidewalk and road acceptance; the Road B cul-de-sac was moved back to allow for room for the proposed SWM facility; generally have shown the location of Village Boulevard; added a note for 100 foot cul-de-sacs, lots 1-48 will be served by AQUA water and sewer and lot 49 by well and septic in the open space acreage; and a plan note was also added about adequate sight distance at the proposed intersections onto Garden Lane. The VDOT Engineer and the Fire and Rescue staff provided the comments that were addressed by the applicant and site consultant for public safety and access.

Following the approval of the Sketch Plan, road plans and design profiles for the rural cluster development shall be submitted for review in addition to review of a preliminary and final plat. Prior to developing the site, the development would require an approved Erosion and Sediment Control Plan reviewed by the E&SC Plans Reviewer to obtain a land disturbing permit and VDEQ and VDOT plan approvals for stormwater management and for road construction plans.

**Conclusion:**

The proposed rural cluster subdivision request has met the requirements of the Fluvanna County Subdivision and Zoning Ordinances and the density and open space requirements of rural cluster subdivisions in the A-1 Zoning District have been met. According to the revised Sketch Plan, the proposed development does not exceed the maximum allowable density of one dwelling unit per two acres, and the required 75% of open space has been provided for in this rural cluster request.

**Recommended Conditions:**

Staff recommends Approval subject to these recommended conditions:

1. The rural cluster subdivision will contain no more than forty-nine (49) separate residential lots, as shown on the revised Sketch Plan dated February 28, 2022;
2. Prior to final plat approval, the applicant shall meet VDEQ and VDOT requirements;
3. Prior to final plat approval, the applicant shall meet Health Department requirements;
4. Preliminary and Final Subdivision plat approvals shall be granted for the use;
5. Site Development Plan and E&SC Plan approvals shall be granted for the use.

**Suggested Motion:**

I move that the Planning Commission (Approve / deny / defer) SUB 22:02 Village Gardens a Sketch Plan request for a rural cluster major subdivision with respect to 116.8 acres of Tax Maps 8 Section A Parcel 18A and 17 Section 9 Parcels 1 and 2, and subject to the five (5) conditions listed in the staff report.

**Attachment:**

Village Gardens Sketch Plan dated February 28, 2022



March 4, 2022

Mr. Douglas Miles, AICP, CZA  
Community Development Director  
Fluvanna Planning & Community Development  
132 Main Street  
Palmyra, Virginia 22963

Dear Mr. Miles:

This letter is to inform you that Aqua Virginia Inc. (Aqua) has sufficient water and wastewater capacity to serve the proposed Village Gardens development consisting of 48 single family detached units. Aqua is also capable of meeting the fire flow demand while our fire pump operates. Based on our hydraulic model, we are not concerned with other customers losing pressure while providing fire flow. The model predicted a system pressure drop of approximately 3 psi when fire flow is provided.

Aqua anticipates that our utility development and service agreement will be finalized shortly after the Planning Commission approval is granted.

Should you have any questions regarding the content of this letter, please feel free to contact me at 804.305.0675 or [TLBlankenship@aquaamerica.com](mailto:TLBlankenship@aquaamerica.com).

Sincerely,

A handwritten signature in black ink that reads "Terry L. Blankenship". The signature is fluid and cursive, with a large loop at the end.

Terry L. Blankenship, P.E.  
State Engineer I  
Aqua Virginia Inc.

cc: John Aulbach II, P.E.  
Charif Soubra

# VILLAGE GARDENS

## SKETCH PLAN

### COUNTY OF FLUVANNA, VIRGINIA

02/28/2022

#### SITE DATA:

TAX MAP PARCELS:  
8-A-18A, 17-9-1, 17-9-2

LEGAL REFERENCES:  
DB 115 PG 388, DB 827 PG 800, DB 827 PG 803

TOTAL PARCEL ACREAGE:  
116.806 AC

ZONING: A-1

MAGISTERIAL DISTRICT: CUNNINGHAM

SOURCE OF BOUNDARY AND TOPOGRAPHY:

TIMMONS GROUP  
28 IMPERIAL DRIVE  
STAUNTON, VA 24401  
TELEPHONE: 540-885-0920  
CONTACT: JOE MEDLEY  
JOE.MEDLEY@TIMMONS.COM

DATUM:

HORIZONTAL: BASED ON NAD83, VIRGINIA STATE GRID SOUTH ZONE.  
VERTICAL: BASED ON NAVD 88

EXISTING USE: VACANT

PROPOSED USE: CLUSTER SUBDIVISION

BUILDING HEIGHT: 35 FT MAXIMUM

BUILDING SETBACKS:

FRONT: 25 FT  
SIDE: 10 FT  
REAR: 25 FT

ROAD FRONTAGE: 60 FT (50 FT ON CUL-DE-SAC)

MAXIMUM GROSS DENSITY ALLOWED: 1 D.U. / 2 ACRES (A-1 ZONING)

MAXIMUM ALLOWABLE LOTS: 58

PROPOSED GROSS DENSITY PROVIDED: 0.84 D.U. / 2 ACRES

PROPOSED NUMBER OF LOTS: 49

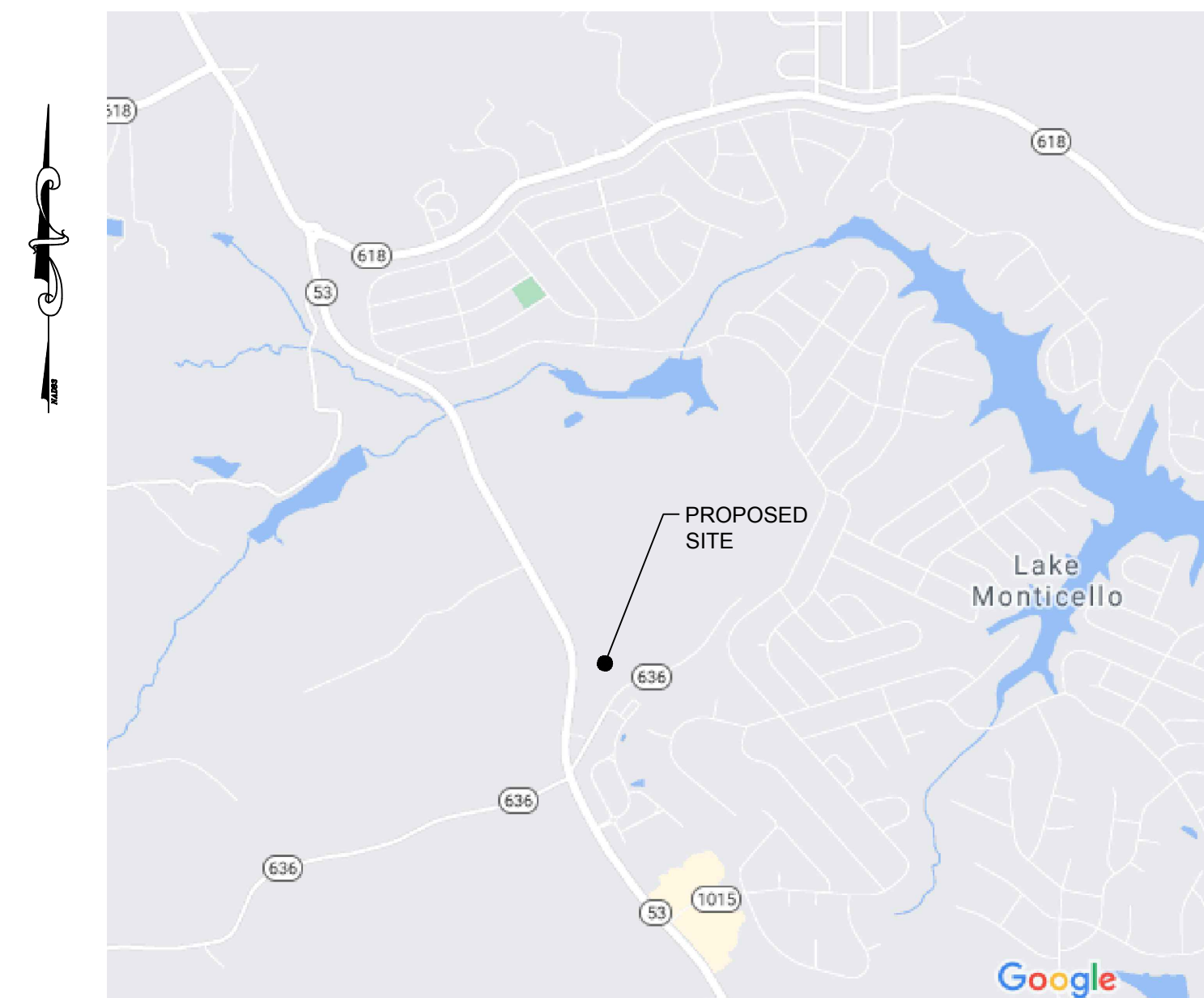

#### VICINITY MAP

SCALE: 1" = 2,000'

#### DEVELOPER:

SOUTHERN DEVELOPMENT HOMES  
142 PANTOPS DR.  
CHARLOTTESVILLE, VA 22911  
CONTACT: KEITH LANCASTER  
TELEPHONE: (434) 245-0894X106  
EMAIL: KLANCASTER@SOUTHERN-DEVELOPMENT.COM

#### ENGINEER OF RECORD:

TIMMONS GROUP  
608 PRESTON AVE. SUITE 200  
CHARLOTTESVILLE, VA 22903  
CONTACT: CLINT SHIFFLETT, PE  
TELEPHONE: (434) 295-5624  
EMAIL: CLINT.SHIFFLETT@TIMMONS.COM

Sheet Index	
Sheet Number	Sheet Title
C0.0	COVER
C1.0	YIELD PLAN
C2.0	CLUSTER PLAN

TOTAL: 3 SHEETS



THIS DRAWING PREPARED AT THE  
**CHARLOTTESVILLE OFFICE**  
608 Preston Avenue, Suite 200 | Charlottesville, VA 22903  
TEL: (434) 295-5624 FAX: (434) 295-8317 www.timmons.com

YOUR VISION ACHIEVED THROUGH OURS.

DATE	REVISION DESCRIPTION
02/28/2022 <td></td>	

DRAWN BY  
*J. FOX*

DESIGNED BY  
*J. FOX*

CHECKED BY  
*C. SHIFFLETT*

SCALE  
1" = 2,000'

**TIMMONS GROUP**

VILLAGE GARDENS  
COUNTY OF FLUVANNA, VIRGINIA

COVER

JOB NO.	48569
SHEET NO.	C0.0



THIS DRAWING PREPARED AT THE  
**CHARLOTTEVILLE OFFICE**  
 608 Preston Avenue, Suite 200 | Charlottesville, VA 22903  
 TEL: 541.235.5624 FAX: 541.235.8317 www.timmons.com

YOUR VISION ACHIEVED THROUGH OURS.

DATE	REVISION DESCRIPTION
02/28/2022 <td></td>	

DRAWN BY  
**J. FOX**

DESIGNED BY  
**J. FOX**

CHECKED BY  
**C. SHIFFLETT**

SCALE  
**1" = 200'**

# TIMMONS GROUP

VILLAGE GARDENS  
 COUNTY OF FLUVANNA, VIRGINIA  
 YIELD PLAN

JOB NO.  
**48569**

SHEET NO.  
**C1.0**

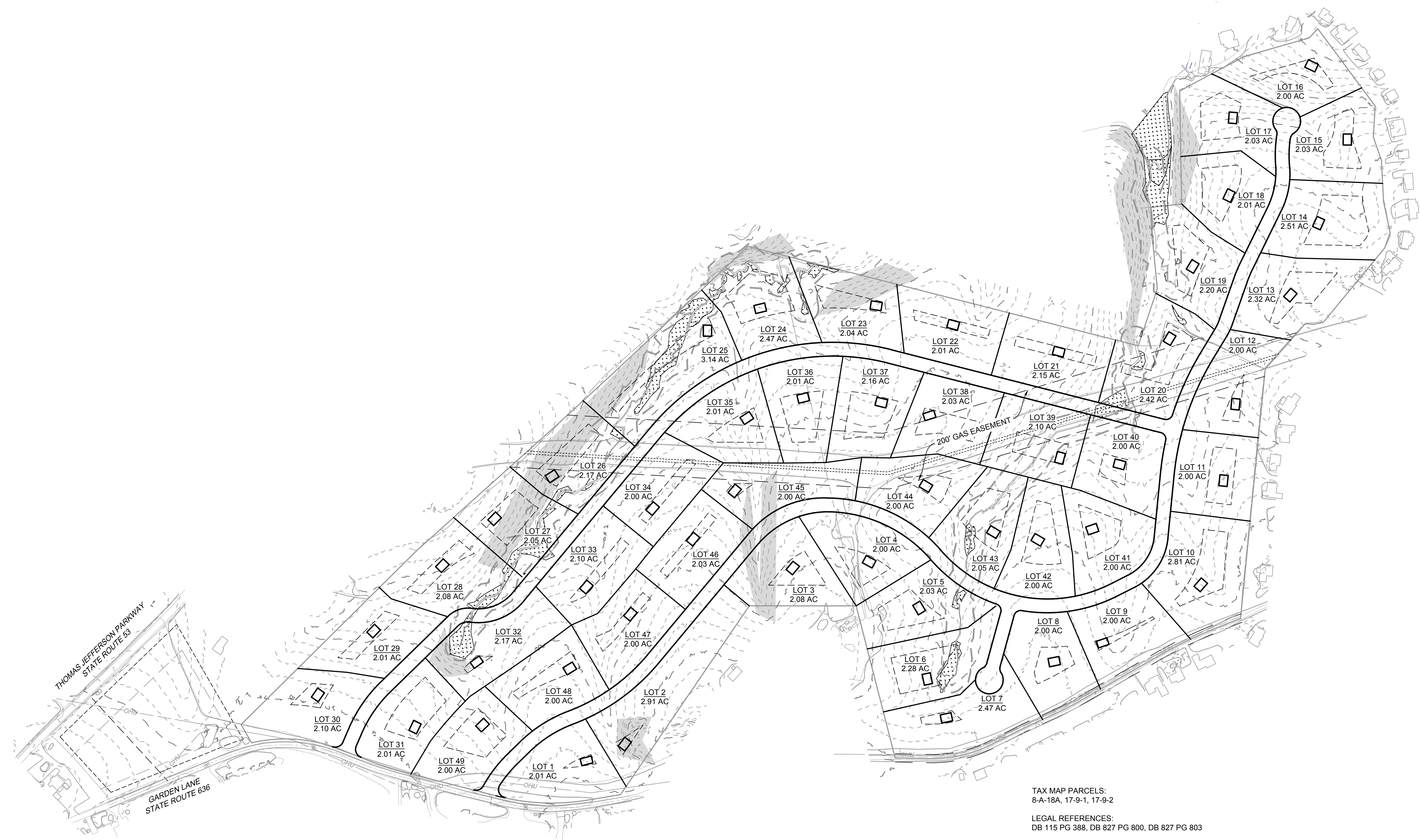

TAX MAP PARCELS:  
 8-A-18A, 17-9-1, 17-9-2

LEGAL REFERENCES:  
 DB 115 PG 388, DB 827 PG 800, DB 827 PG 803

TOTAL PARCEL ACREAGE:  
 116.806 AC

ZONING: A-1

MAGISTERIAL DISTRICT: CUNNINGHAM

BUILDING SETBACKS:

FRONT:	125 FT
SIDE:	50 FT
REAR:	75 FT

ROAD FRONTAGE: 300 FT

MINIMUM LOT AREA: 87,120 SF

MAXIMUM GROSS DENSITY ALLOWED: 1 D.U. / 2 ACRES (A-1 ZONING)

MAXIMUM ALLOWABLE LOTS: 58

PROPOSED GROSS DENSITY PROVIDED: 0.84 D.U. / 2 ACRES

PROPOSED NUMBER OF LOTS: 49

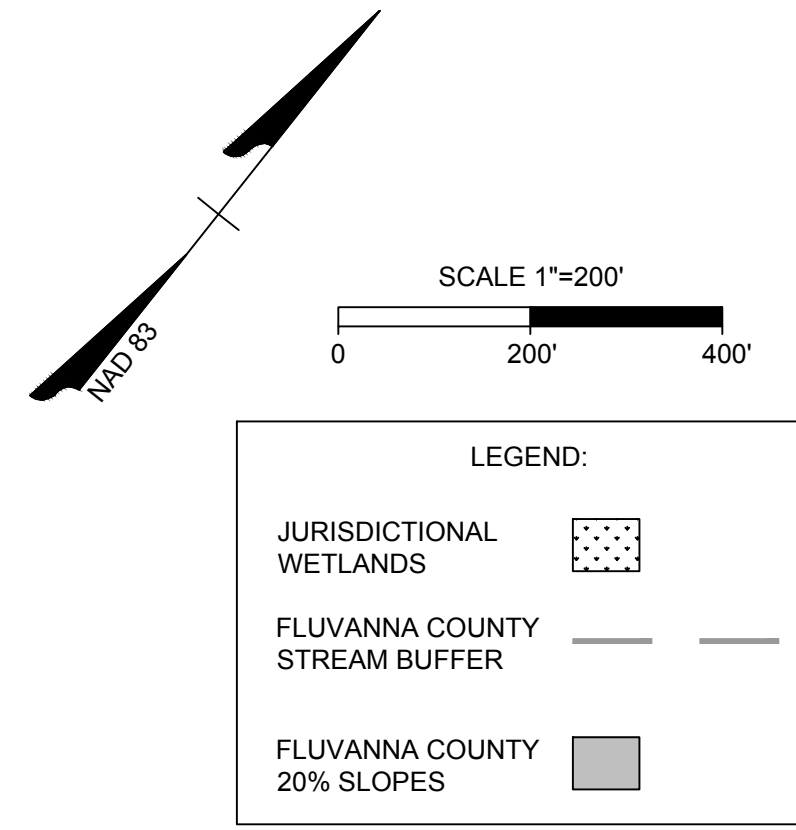

S:\10348869-Nahor (Village Gardens)\DWG\C01.0 - VG\_YIELD.dwg | Plotted on 2/28/2022 4:58 PM | by Clint Shifflett

These plans and associated documents are the exclusive property of TIMMONS GROUP and may not be reproduced in whole or in part and shall not be used for any purpose whatsoever, in whole, but not limited to construction, bidding, and/or construction staking without the express written consent of TIMMONS GROUP.

**TYPICAL ROAD CROSS SECTION**  
(25 MPH DESIGN SPEED)

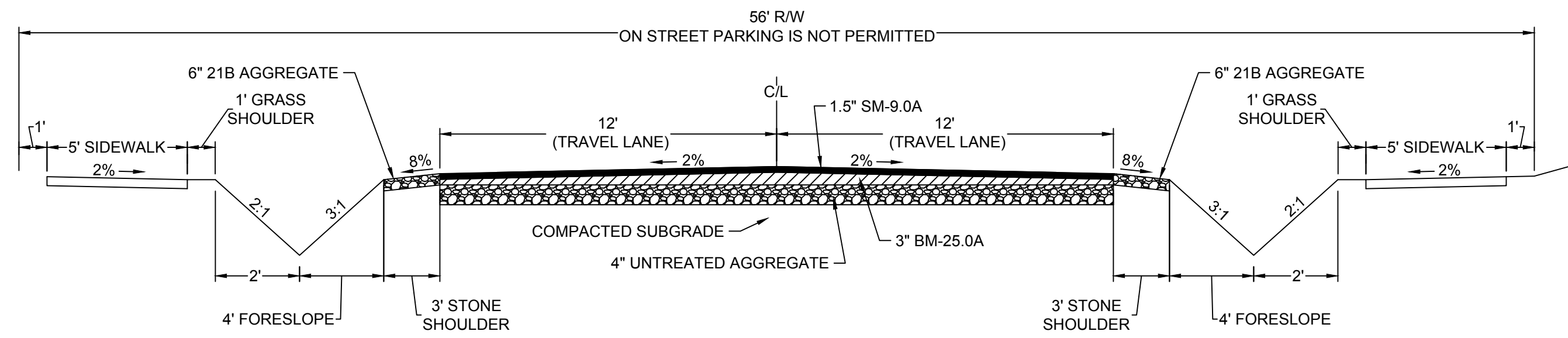

NOTE: ROAD CROSS SECTION COMPLIES WITH VDOT SSAR DESIGN STANDARDS.

**TYPICAL ROAD CROSS SECTION**

No Scale

TAX MAP PARCELS:  
8-A-18A, 17-9-1, 17-9-2

LEGAL REFERENCES:  
DB 115 PG 388, DB 827 PG 800, DB 827 PG 803

TOTAL PARCEL ACREAGE:  
116.806 AC

ZONING: A-1

MAGISTERIAL DISTRICT: CUNNINGHAM

BUILDING SETBACKS:

FRONT: 25 FT  
SIDE: 10 FT  
REAR: 25 FT

ROAD FRONTAGE: 60 FT (50 FT ON CUL-DE-SAC)

MINIMUM LOT AREA: 15,000 SF

MAXIMUM GROSS DENSITY ALLOWED: 1 D.U. / 2 ACRES (A-1 ZONING)

MAXIMUM ALLOWABLE LOTS: 58

PROPOSED GROSS DENSITY PROVIDED: 0.84 D.U. / 2 ACRES

PROPOSED NUMBER OF LOTS: 49

**CLUSTER LOT AREA SUMMARIES**

LOT 1	16,048 SF
LOT 2	16,048 SF
LOT 3	16,048 SF
LOT 4	15,000 SF
LOT 5	15,000 SF
LOT 6	15,000 SF
LOT 7	15,083 SF
LOT 8	16,760 SF
LOT 9	15,999 SF
LOT 10	23,365 SF
LOT 11	18,002 SF
LOT 12	15,000 SF
LOT 13	15,000 SF
LOT 14	15,000 SF
LOT 15	15,000 SF
LOT 16	15,000 SF
LOT 17	15,000 SF
LOT 18	15,000 SF
LOT 19	15,000 SF
LOT 20	17,674 SF
LOT 21	16,617 SF
LOT 22	15,989 SF
LOT 23	15,264 SF
LOT 24	15,187 SF
LOT 25	15,187 SF
LOT 26	15,187 SF
LOT 27	15,187 SF
LOT 28	15,301 SF
LOT 29	18,893 SF
LOT 30	15,243 SF
LOT 31	15,201 SF
LOT 32	15,201 SF
LOT 33	15,201 SF
LOT 34	15,201 SF
LOT 35	16,080 SF
LOT 36	15,459 SF
LOT 37	15,178 SF
LOT 38	16,384 SF
LOT 39	15,402 SF
LOT 40	15,091 SF
LOT 41	15,007 SF
LOT 42	17,221 SF
LOT 43	16,881 SF
LOT 44	21,305 SF
LOT 45	15,847 SF
LOT 46	15,847 SF
LOT 47	15,847 SF
LOT 48	15,847 SF
LOT 49	4,074,602 SF (OPEN SPACE)

TOTAL LOTS: 49  
TOTAL RIGHT-OF-WAY: 4.33 AC ( 4% OF PARCEL AREA)  
TOTAL OPEN SPACE: 93.54 AC (80% OF PARCEL AREA)  
TOTAL PARCEL AREA: 116.81 AC

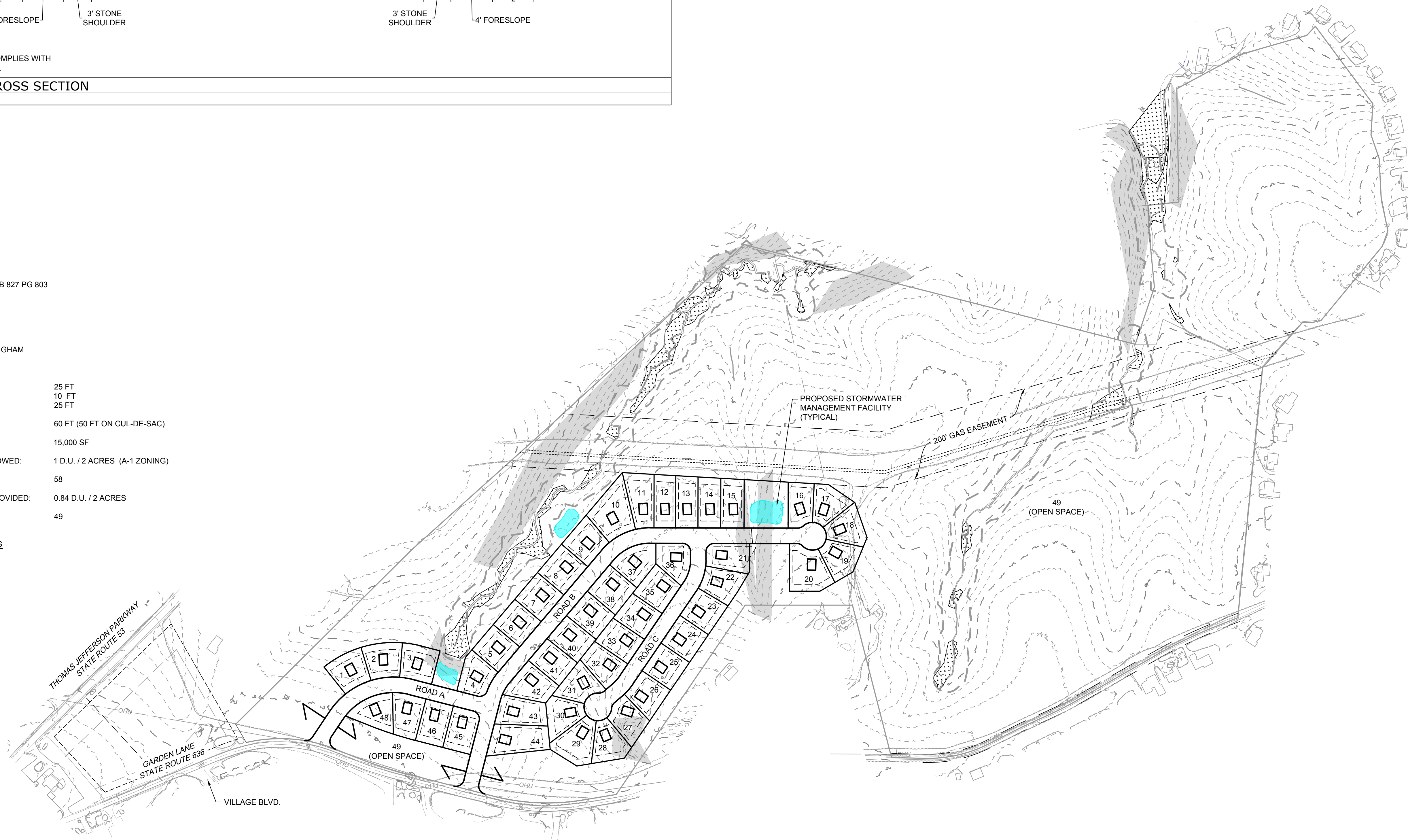

**NOTES:**

- CUL-DE-SACS SHALL BE 100' DIAMETER.
- WATER AND SEWER SERVICE FOR LOTS 1-48 SHALL BE PROVIDED BY AQUA VIRGINIA. LOT 49 SHALL BE SERVED BY PRIVATE WELL AND SEPTIC.
- ADEQUATE SIGHT DISTANCE SHALL BE PROVIDED AT EACH PROPOSED INTERSECTION.

SEC. 22-4-10.3 RURAL CLUSTER REGULATIONS.  
(ORD. 6-15-05)

- (4) NOTHING CONTAINED HEREIN SHALL BE CONSTRUED TO PREVENT THE USE OR DEVELOPMENT OF ANY OPEN SPACE PARCEL FOR ONE OR MORE OF THE FOLLOWING:  
(A) THE CONSTRUCTION OF A SINGLE FAMILY RESIDENCE, PROVIDED THAT SUCH RESIDENCE SHALL BE INCLUDED IN THE CALCULATION OF MAXIMUM GROSS DENSITY PERMITTED FOR THE CLUSTER OPTION DEVELOPMENT.

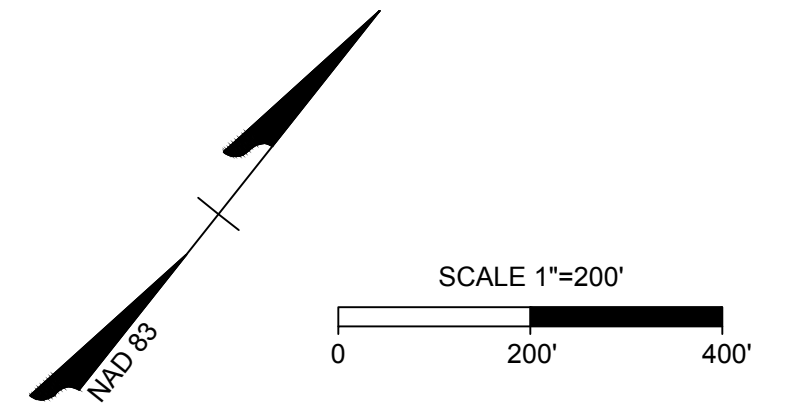

LEGEND:	
JURISDICTIONAL WETLANDS	
FLUVANNA COUNTY STREAM BUFFER	
FLUVANNA COUNTY 20% SLOPES	

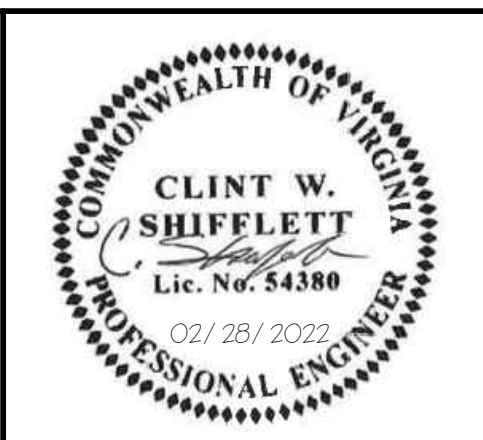

THIS DRAWING PREPARED AT THE  
**CHARLOTTEVILLE OFFICE**  
608 Preston Avenue, Suite 200 | Charlottesville, VA 22903  
TEL: 541.235.5624 | FAX: 541.235.8317 | www.timmons.com

YOUR VISION ACHIEVED THROUGH OURS.	REVISION DESCRIPTION
DATE	
02/28/2022	
DRAWN BY	J. FOX
DESIGNED BY	J. FOX
CHECKED BY	C. SHIFFLETT
SCALE	1" = 200'

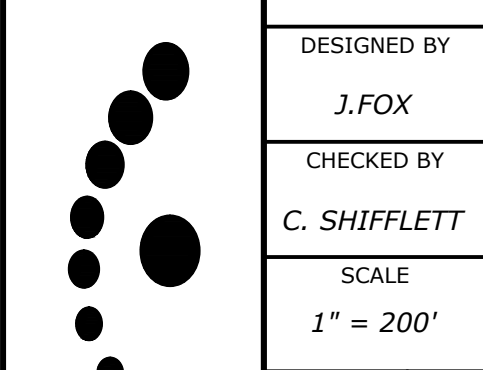

**TIMMONS GROUP**

VILLAGE GARDENS  
COUNTY OF FLUVANNA, VIRGINIA  
CLUSTER PLAN

JOB NO.  
**48569**

SHEET NO.  
**C2.0**

These plans and associated documents are the exclusive property of TIMMONS GROUP and may not be reproduced in whole or in part and shall not be used for any purpose whatsoever, inclusive, but not limited to construction, bidding, and/or construction staking without the express written consent of TIMMONS GROUP.

Reset Form



# COMMONWEALTH OF VIRGINIA COUNTY OF FLUVANNA Subdivision Application

RECEIVED Print Form

FEB 01 2022

Fluvanna County  
Planning Dept

**Owner of Record:** see attached  
E911 Address: \_\_\_\_\_  
Phone: \_\_\_\_\_ Fax: \_\_\_\_\_  
Email: \_\_\_\_\_

**Applicant of Record:** Southern Development  
E911 Address: 142 South Pantops Drive  
Phone: 434-245-0894 Fax: 434-245-0895  
Email: klmcarter@southern-development.com

**Tax Map and Parcel(s):** 8A-18A, 179-1, 179-2  
**Acreage:** 116.8 **Zoning:** A-1 **Number of Lots:** 49 (dist)  
**Surveyor:** Timmons Group  
**Subdivision Name:** Village Garden  
E911 Address of Parcel: \_\_\_\_\_  
**Description of Property:** vacant

**Note: If applicant is anyone other than the owner of record, written authorization by the owner designating the applicant as the authorized agent for all matters concerning the request shall be filed with this application.**

Is property in Agricultural Forestal District?  No  Yes  
If Yes, what district: \_\_\_\_\_

**Deed Book Reference:** DB115 p. 388, DB 827 p. 800, DB 827 p. 803  
Deed Restrictions?  No  Yes (Attach copy)

Please check appropriate box:

Type	Forms Required
<input type="checkbox"/> Minor - 2-5 Lots	Sketch Plan Checklist Preliminary Subdivision Checklist Final Subdivision Checklist
<input checked="" type="checkbox"/> Major - 6+ Lots	Sketch Plan Checklist Preliminary Subdivision Checklist Final Subdivision Checklist

I declare that the statements made and information given on this application are true, full and correct to the best of my knowledge and belief. I agree to conform fully to all terms of any certificate or permit which may be issued on account of this application.

Keith Lancaster  
Applicant Name (Please Print)

[Signature]  
Applicant Signature

All plats must be folded prior to submission to the Planning Department for review. Rolled plats will not be accepted.

OFFICE USE ONLY		
Date Received: <u>02/01/2022</u>	Fee Paid: check 2706 \$4,450.00	Application #: <u>SUB 22 : 02</u>
Election District: <u>Cunningham</u>	Planning Area: <u>Rivanna Community</u>	Number of Lots: <u>49</u>
<b>Minor (2-5 Lots)</b>	<b>Major (6 or more Lots)</b>	
\$ 500.00 + GIS Fee	\$1,000.00 + GIS Fee	Approval/Denial Date:
Resubmission of Preliminary or Final Plat: \$100.00		Approval/Denial Date:
GIS Fee: \$ 50.00 per lot (residue is considered a lot)		
<b>Additional Fees Due at Time of Review</b>		
Road Maintenance Agreement Review: \$200.00	Revisions: \$50.00	
Dedication Common Lands Document Review: \$200.00	Revisions: \$50.00	
Homeowner Association Document Review: \$200.00	Revisions: \$50.00 ✓	
Health Department Subdivision Review: \$250.00 + \$25.00 per lot	Existing System Review \$50.00	
Street Sign Installation: \$200.00 Per Intersection	<u>4</u> ✓	

## **Additional Ownership information**

### **Current Owners of Record:**

- 17-9-1, Haden, Lisa Michelle, 2195 Pendleton PL Suwanee GA 30024
- 17-9-2, Galaska, Louise, 4665 Lambton Circle Suwanee GA 30024
- 8-A-18A, Fox, Priscilla Forstbauer, 1425 Gentry Lane Charlottesville VA 22903 (DB 115-388)

### **Current Zoning and Acreage:**

- 17-9-1, A-1 – 49.78
- 17-9-2, A-1 – 49.78
- 8-A-18A, A-1 – 17.24ac



---

# COUNTY OF FLUVANNA

---

*"Responsive & Responsible Government"*

132 Main Street  
P.O. Box 540  
Palmyra, VA 22963  
(434) 591-1910  
Fax (434) 591-1911  
[www.fluvannacounty.org](http://www.fluvannacounty.org)

## MEMORANDUM

To: Fluvanna County Planning Commissioners

From: Douglas Miles, Community Development Director **DM**

Date: March 8, 2022

Subject: **2040 Comprehensive Plan – Resident Advisory Group Selections**

On March 8th during the Planning Commission Regular Meeting you will be finalizing your selections for these three (3) groups to begin the plan work in the Spring of 2022.

Please find the attached Fluvanna County residents who have applied to serve on:

1. Rural Crossroads Areas (RCA) and Rural Preservation Advisory Group

This will be the main Resident Advisory Group and with up to six (6) residents and up to two (2) Planning Commissioners along with planning staff members.

2. Zions Crossroads Gateway Plan Stakeholders Group

This will be up to three (3) Fluvanna County residents that have architectural design and urban and regional planning backgrounds along with the existing stakeholders group comprised of County Staff and technical planning staff.

3. Fluvanna County Historical Preservation Advisory Group

This will be up to three (3) Fluvanna County residents that may have both art historian and architectural backgrounds and may have even served on the Fluvanna Historical Society to review any historically significant sites.

Please call me with questions at 434.591.1910 or e-mail at [dmiles@fluvannacounty.org](mailto:dmiles@fluvannacounty.org)





## APPLICATION TO SERVE ON COMPREHENSIVE PLAN SUBCOMMITTEE County of Fluvanna

Fluvanna County does not discriminate on the basis of race, color, national origin, sex, religion, age, or disability in employment or the provision of services. Before completing the application, please review the membership requirements for the Board, Commission, or Committee for which you are interested. Applicants who do not meet membership requirements will not be put forward for consideration.

Name: <b>Joshua Bower</b>	Election <input type="checkbox"/> Columbia <input checked="" type="checkbox"/> Cunningham <input type="checkbox"/> Fork Union District: <input type="checkbox"/> Palmyra <input type="checkbox"/> Rivanna <input type="checkbox"/> Other
EXPERIENCE/PROFESSIONAL EXPERTISE/EDUCATION (Please provide dates of education and experience. You may also provide a resume/CV.): I have an Associates Degree in Architecture from Penn College (1994-96) and a Bachelors Degree in Architecture from Temple University (1996-2002). I am a licensed Architect in Virginia and have been a partner in my firm since 2017. I have been practicing Architecture since 1998.	
CURRENT OR PRIOR SERVICE ON BOARDS/COMMISSIONS/OR COMMITTEES: I have served as an elected member of Mount Joy PA Borough Council for 7 years (President Pro-tem for 2 years), Mount Joy PA planning commission for 9 years (chair for 4 years), Mount Joy PA Main Street executive board for 5 years, Building Committee on Main Street Org for 5 years and at Church for over 10 years. I was elected as Judge of Elections for (2) four year terms. I also served on the St Marks UMC leadership team for 6 years and chair for two of those years.	
CIVIC ACTIVITIES AND MEMBERSHIPS (Roles with fraternal, business, church, or social groups – please provide dates): I have been a member of Sigma Phi Epsilon Fraternity in college and a member of Rotary International in Mount Joy PA. I am currently a member the American Institute of Architects and of the National CPTED Organization.	
REASON(S) FOR WANTING TO SERVE FLUVANNA COUNTY: My family and I moved here from Pennsylvania in 2015. When in PA I was fortunate to dedicate some of my personal time to help make the community better through governmental, economic development and spiritual organizations. As our children are now moving onto college, I would like to start seeking opportunities to dedicate some of my personal time to Fluvanna County and its residents.	

**PLEASE INDICATE BELOW THE SUBCOMMITTEE(S)  
ON WHICH YOU WISH TO SERVE.**

X	SUBCOMMITTEE	DESCRIPTION
X	Future Land Use-Zion Crossroads Gateway Plan Subcommittee	Subcommittee will discuss mixed-use commercial, industrial, and higher-density residential uses with well-planned transportation improvements and gateway design standards in conjunction with Louisa County.
	Rural and Historic Preservation Subcommittee	Subcommittee will work to review Rural Cluster provisions, to enhance the Rural Preservation options, and further identify Fluvanna County's historical buildings and places.

**Submit by email ([clerk@fluvannacounty.org](mailto:clerk@fluvannacounty.org)) or mail to:  
County of Fluvanna, Attention: Clerk, Board of Supervisors, PO Box 540, Palmyra, VA 22963**

In accordance with Virginia Code §2.2-3705.1, by submitting this application, it is presumed that you are providing your personal contact information to be used for communicating with the County, and unless otherwise indicated by you, your personal contact information will not be shared publicly.

Applicant's Signature <b>Joshua Bower</b>		Date <b>01-13-2022</b>	
Mailing Address (including City, State, & ZIP) <small>418 Fox Hollow Lane, Palmyra, VA 22963</small>		Physical Address (if different)	
Years Lived in Fluvanna <b>6</b>	Phone # <b>434-989-2788</b>	Alternate Phone #	Email Address <b>bowerjc00@gmail.com</b>
<b>Office Use Only</b>			
Application Received On:	<b>1-13-2022</b>	Application Received By: <b>Leontyne Peck</b>	
Acknowledgement Sent:	<b>1-13-2022</b>		
Renewal Date:		Remarks:	
Renewal Date:			
Renewal Date:			
Renewal Date:			



## APPLICATION TO SERVE ON COMPREHENSIVE PLAN SUBCOMMITTEE County of Fluvanna

Fluvanna County does not discriminate on the basis of race, color, national origin, sex, religion, age, or disability in employment or the provision of services. Before completing the application, please review the membership requirements for the Board, Commission, or Committee for which you are interested. Applicants who do not meet membership requirements will not be put forward for consideration.

Name: <b>Donna Daguanno</b>	Election <input type="checkbox"/> Columbia <input checked="" type="checkbox"/> Cunningham <input type="checkbox"/> Fork Union District: <input type="checkbox"/> Palmyra <input type="checkbox"/> Rivanna <input type="checkbox"/> Other
EXPERIENCE/PROFESSIONAL EXPERTISE/EDUCATION (Please provide dates of education and experience. You may also provide a resume/CV.):  <b>See Attached Resume</b>	
CURRENT OR PRIOR SERVICE ON BOARDS/COMMISSIONS/OR COMMITTEES:	
CIVIC ACTIVITIES AND MEMBERSHIPS (Roles with fraternal, business, church, or social groups – please provide dates):  <b>See Attached Resume</b>	
REASON(S) FOR WANTING TO SERVE FLUVANNA COUNTY:  <b>To Be Civically Active</b>	

**PLEASE INDICATE BELOW THE SUBCOMMITTEE(S)  
ON WHICH YOU WISH TO SERVE.**

X	SUBCOMMITTEE	DESCRIPTION
X	Future Land Use-Zion Crossroads Gateway Plan Subcommittee	Subcommittee will discuss mixed-use commercial, industrial, and higher-density residential uses with well-planned transportation improvements and gateway design standards in conjunction with Louisa County.
X	Rural and Historic Preservation Subcommittee	Subcommittee will work to review Rural Cluster provisions, to enhance the Rural Preservation options, and further identify Fluvanna County's historical buildings and places.

<p><b>Submit by email (<a href="mailto:clerk@fluvannacounty.org">clerk@fluvannacounty.org</a>) or mail to:</b>  <b>County of Fluvanna, Attention: Clerk, Board of Supervisors, PO Box 540, Palmyra, VA 22963</b></p> <p>In accordance with Virginia Code §2.2-3705.1, by submitting this application, it is presumed that you are providing your personal contact information to be used for communicating with the County, and unless otherwise indicated by you, your personal contact information will not be shared publicly.</p>			
Applicant's Signature <b>Donna Daguanno</b>		Date 11/22/2021	
Mailing Address (including City, State, & ZIP) <b>148 Crape Myrtle Dr Palmyra Va 22963</b>		Physical Address (if different)	
Years Lived in Fluvanna 2 1/2 years	Phone # <b>3129537029</b>	Alternate Phone #	Email Address <b>ddaguanno@aol.com</b>
<b>Office Use Only</b>			
Application Received On:	11/23/2021	Application Received By: Caitlin Solis	
Acknowledgement Sent:	11/23/2021		
Renewal Date:		Remarks:	
Renewal Date:			
Renewal Date:			
Renewal Date:			

DONNA D'AGUANNO  
148 Crape Myrtle Drive, Palmyra VA 22963  
434-510-7470 (H) 312-953-7029 (Cell/Office)  
[donna@daguannogroup.com](mailto:donna@daguannogroup.com)  
Southern Illinois University | BS | Photography

## Career Focus

Dynamic and creative Marketing Manager with a successful career in sales, communication management, product marketing, public relations and promotions.

## Summary of Skills

- Skilled in sophisticated sales techniques incorporating the presentation of intangible product benefits  
innovative thinker, able to quickly and effectively resolve problems
- Demonstrated success in gaining multi-million dollar sales growth in competitive market
- Accomplished trainer and developer of personnel
- Prospect, engage and qualify C-Level clients through clear and articulate communication and presentation skills
- Local, National and International Network gaining client loyalty and maintaining strong long-term relationships
- Strategic and tactical development leading to YOY growth for multiple, national and international companies
- Negotiating, Budget Development and Tactical Project Management
- Adept at opening business opportunities in closed market situations

## Professional Experience

D'Aguanno Group  
CEO/Principal Owner  
Oak Park, IL

Fall 1981 to Present

Represented award winning television commercial production companies, photographers and directors to the nation's leading advertisers. With a focus on account development and relationship management was able to secure accounts and build multi-million dollar revenue

Clients Include: McDonald's, Disney, Chrysler/Jeep, Ford Motor Company, Sears and other Fortune 500 companies.

- Targeted and secured high profile accounts that resulted in national award winning television commercials and print campaigns, including Super Bowl commercials
- Interfaced with clients during all facets of production and post-production to assure all expectations were met on-time and on-budget
- Skilled in event management to facilitate client networking, introduce new and established talents to clientele and preview new work of directors and photographers
- Ability to succeed and maintain perspective in a fast-paced, rapidly evolving highly competitive environment
- Experienced working with international business partners in complex negotiations
- Provided an outlet for clients to address concerns or expectations on projects and worked closely with them toward an effective resolution
- Outstanding written, and expert verbal presentation and management skills
- Conceived, developed and successfully implemented a new model for talent management establishing a change from the former 40 year system and creating a new best practice within commercial talent management
- Office management software: Microsoft Word, Excel, Power Point

## **Professional Experience Continued**

The White House  
1600 Pennsylvania Avenue, N.W.  
Washington, DC 20500

Fall 1980 to Summer 1981

### **Photo Editor**

Worked in the President's personal photo office for President Jimmy Carter and President Ronald Reagan. The office covered the President's official day-to-day duties.

- Selected photographs exclusive to the White House photo office to publications.
- Handled day to day correspondence with citizens requesting specific photographs of events

## **Professional Associations**

**Frank Lloyd Wright Preservation Trust – Frank Lloyd Wright Home and Studio**  
2005-2011

### **Tour Interpreter**

Developed personalized 50 minute tour for visitors at Frank Lloyd Wright Home and Studio with precise and accurate information

### **Mentor Training for Frank Lloyd Wright Home and Studio**

Mentored new volunteers in the Interpreter Training program which is a concentrated three-week study, including readings, class lectures and workshops toward conducting tours of The Frank Lloyd Wright Home and Studio

### **House Captain for Home and Studio for yearly Wright Plus House Walk Fundraiser**

Wright Plus is a one-day event hosting over 2,000 visitors involving 450 volunteers to help promote the educational mission at the Preservation Trust and promote the largest fund-raising event of the year

- Prepared materials for 31 stations on the tour assuring correct and concise content
- Work with the 45 volunteers to understand expectations for day of tour
- Trained volunteers on logistics for the day of tour
- Provided emergency information and clear directions for emergency routes
- Prepared schedule for volunteer stations for day of event – rotating 45 volunteers over 31 stations
- Work day of the event to coordinate proper flow for visitors moving through the tour
- Insure the safety of the visitors, volunteers and museum
- Directed and encouraged visitor to the museum shop

## References

Jean Kengott  
208 South Evergreen Road  
Arlington Heights, IL 60005  
847-738-1654 (cell)  
847-670-1654 (work)  
jckengott@msn.com

Kristine Masta  
375 La Marido  
Pittsburgh, PA 15226  
412-668-0949 (cell)  
kristine@kristinemasta.com

Cami Taylor  
2232 North Gower Street  
Los Angeles, CA 90068  
213-590-1414 (cell)  
camitaylor@aol.com

Wil Wilcox  
6024 Sedgley Court  
Burr Ridge, IL 60527  
630-655-3528 (work)  
312-315-2168 (cell)  
wilcoxw@comcast.net



# APPLICATION TO SERVE ON COMPREHENSIVE PLAN SUBCOMMITTEE

## County of Fluvanna

Fluvanna County does not discriminate on the basis of race, color, national origin, sex, religion, age, or disability in employment or the provision of services. Before completing the application, please review the membership requirements for the Board, Commission, or Committee for which you are interested. Applicants who do not meet membership requirements will not be put forward for consideration.

Name: <b>Marie Deverneil</b>	Election: <input checked="" type="checkbox"/> Columbia <input type="checkbox"/> Cunningham <input type="checkbox"/> Fork Union
	District: <input type="checkbox"/> Palmyra <input type="checkbox"/> Rivanna <input type="checkbox"/> Other

**EXPERIENCE/PROFESSIONAL EXPERTISE/EDUCATION (Please provides dates of education and experience. You may also provide a resume/CV.):**

Ph.D. French Studies, The Catholic University of America, Washington, D.C., 1993.  
 a) M.A. Instructional Systems Development (ISD) program at UMBC, Baltimore, MD, Training Track, Specialization in CBT (Computer-based Training) and Distance Learning, May 1999.  
 b) M.A. French Literature, The Catholic University of America, Washington, D.C., 1981.  
 Distance Education Certificate, UMBC, 1998: Distance Education, Corporate Distance Training  
 Computer-Based Training Certificate, UMBC, 1997.  
 B.A., Arts and Sciences, French major and philosophy minor, Central Michigan University, Mt. Pleasant, Michigan, 1978.

Employment in Higher Education

2005-2020: Senior lecturer of French, UMBC  
 Courses regularly taught: French 101-301, Relevant course: MLL 240 (from 2008 to 2020)  
 I designed and taught a new course on Cultural Sustainability, which examines the impact of globalization on the planet following principles of sustainability and offers means to assess green solutions and involvement feasibility in diverse local social entrepreneurship ventures. The course development was funded by a CASH/Kaufman Grant at UMBC on Social Entrepreneurship and Innovation.

1999-2020: French Language coordinator  
 Supervision, mentoring and training of Teaching Assistants and Part-Time Faculty Design, implementation and articulation of the C hour instruction sequence, and curriculum design, and development of the French 101-201 program.

1987- 1998 Editor-in-Chief and senior writer of Les Cahiers Pédagogiques for France-TV Magazine: a 60 minute French language television magazine on France, Europe, and the francophone world, Distributed nationally by PBS's Adult Learning Service (ALS), PBS's Elementary and Secondary School Service (ESS) by Simon & Schuster Custom Publishing. International distribution by the French Ministry of Foreign Affairs and the Délégation Générale à la Langue Française.

1998-2005: Lecturer of French, UMBC  
 1996-1999: Half-time Lecturer of French, UMBC  
 1992-1996: Half-Time Instructor of French, UMBC  
 1984- 1991: Part-time Instructor of French, UMBC

**CURRENT OR PRIOR SERVICE ON BOARDS/COMMISSIONS/OR COMMITTEES:**

Departmental and University Committees:  
 Articulation Coordinator (2018-2020)  
 Blackboard Advisory Board (2005-2012)  
 Instructional Technology Committee (1998-2000)  
 Local Committees Howard County, FL Advisory Committee (2003-2006)  
 National Committees Member, AATF Committee on Media and Technology in the Teaching of French (Task Force on the Promotion of French in the U.S.) (1997-2000)  
 Member, AATF Commission on Cultural Competence (1997-2000)  
 Student organizations and International Living Exchange at UMBC  
 French Club advisor ( 2000-2017)  
 ILE Director ( 2005-2020)  
 French Liaison for the French Cluster in the ILE. (2002- 2005)  
 ILE coordinator ( 2016-2020) French conversation Coordinator. (2000-2020)  
 Staffing, management and articulation with French Faculty for Beginner, Intermediate, and Advanced students.

**CIVIC ACTIVITIES AND MEMBERSHIPS (Roles with fraternal, business, church, or social groups – please provide dates):**

**At UMBC**  
 Member of Sustainability Matters student organization group (up to 2020)  
 Community garden advisor (2010-2015)  
 Member of Byrd Chapel (2010-present)  
 President of Ellicott City, MD Normandy Heights Community Association (1994-1996)

**REASON(S) FOR WANTING TO SERVE FLUVANNA COUNTY:**

I am very concerned with preserving Fluvanna's rural character. Since I bought my property in 1996, I have seen a steady decline in both flora and fauna diversity. I am also concerned with the fact that the designated Rural Preservation Areas have actually seen, as of 2017, the highest percentage of growth (56%). The latest census is showing less than 10% growth population, which means that we could have a say in development in rural areas.

I have taught courses on globalization, and sustainability for over 20 years, and think I may be of help. I am now retired and living full time in Fluvanna and would like to be engaged.

Thank you



**PLEASE INDICATE BELOW THE SUBCOMMITTEE(S)  
ON WHICH YOU WISH TO SERVE.**

X	SUBCOMMITTEE	DESCRIPTION
	Future Land Use-Zion Crossroads Gateway Plan Subcommittee	Subcommittee will discuss mixed-use commercial, industrial, and higher-density residential uses with well-planned transportation improvements and gateway design standards in conjunction with Louisa County.
X	Rural and Historic Preservation Subcommittee	Subcommittee will work to review Rural Cluster provisions, to enhance the Rural Preservation options, and further identify Fluvanna County's historical buildings and places.

<p><b>Submit by email (<a href="mailto:clerk@fluvannacounty.org">clerk@fluvannacounty.org</a>) or mail to:</b>  <b>County of Fluvanna, Attention: Clerk, Board of Supervisors, PO Box 540, Palmyra, VA 22963</b></p> <p>In accordance with Virginia Code §2.2-3705.1, by submitting this application, it is presumed that you are providing your personal contact information to be used for communicating with the County, and unless otherwise indicated by you, your personal contact information will not be shared publicly.</p>			
Applicant's Signature		Date	
<i>Marie DeVerneil</i>		11/04/2021	
Mailing Address (including City, State, & ZIP)		Physical Address (if different)	
<small>1118 mountain Laurel Road, Palmyra, Va 22963</small>			
Years Lived in Fluvanna	Phone #	Alternate Phone #	Email Address
<small>part time since 1996 full time since 2020</small>	434-3737890	410-3755944	devernei@umbc.edu
<b>Office Use Only</b>			
Application Received On:	11/04/2021	Application Received By: Caitlin Solis	
Acknowledgement Sent:	11/10/2021		
Renewal Date:		Remarks:	
Renewal Date:			
Renewal Date:			
Renewal Date:			



## APPLICATION TO SERVE ON COMPREHENSIVE PLAN SUBCOMMITTEE County of Fluvanna

Fluvanna County does not discriminate on the basis of race, color, national origin, sex, religion, age, or disability in employment or the provision of services. Before completing the application, please review the membership requirements for the Board, Commission, or Committee for which you are interested. Applicants who do not meet membership requirements will not be put forward for consideration.

Name: <b>Thomas Diggs</b>	Election <input type="checkbox"/> Columbia <input type="checkbox"/> Cunningham <input type="checkbox"/> Fork Union <input checked="" type="checkbox"/> Palmyra <input type="checkbox"/> Rivanna <input type="checkbox"/> Other
EXPERIENCE/PROFESSIONAL EXPERTISE/EDUCATION (Please provide dates of education and experience. You may also provide a resume/CV.): B.S., Liberty University, 1974; M.Ed., University of Lynchburg, 1979; Ed.D., University of Virginia, 1986; Certificate, Harvard University, 1987; J.D., College of William and Mary, 1993, Fellow (Honorary), Institute for Court Management Liberty University (1973-1990), final position was Associate Provost, Dean of the School of LifeLong Learning, and Associate Professor of Education National Center for State Courts (1991-1998), final position was Senior Educator and Director, Court Executive Development Program Thomas M. Diggs, Attorney at Law (1995-2005 and 2008-date), retired, but still providing pro bono legal services Regent University (1998-2004), final position was Associate Dean, School of Law, Director, International Tax Program, and Associate Professor of Law Supreme Court of Virginia (2005-2008), final position was Assistant Director of Judicial Programs	
CURRENT OR PRIOR SERVICE ON BOARDS/COMMISSIONS/OR COMMITTEES: Member of Visiting Teams for Southern Association of Colleges and Schools, Transnational Association of Christian Colleges and Schools, and State Council of Higher Education for Virginia James Kent American Inn of Court, Master and Administrator Committee on Continuing Legal Education, Virginia Law Foundation Commission on Virginia Courts in the 21st Century (staff director for this Supreme Court of Virginia commission) Commission on Mental Health Law Reform (staff director for this Supreme Court of Virginia commission)	
CIVIC ACTIVITIES AND MEMBERSHIPS (Roles with fraternal, business, church, or social groups – please provide dates): Unit Campaign Chairman for the United Way (1989-90) President, Lafayette High School Choral Boosters Association (1997-98) Volunteer, The City Choir of Washington (2008-2012) Pro bono legal services (1995 to date) Bar memberships: Supreme Court of Virginia (1993 on), Supreme Court of the United States (1998 on), US Court of Appeals for the Fourth Circuit (1993 on), US Court of Appeals for the Armed Forces (1996 on), US District Court for the Eastern District of Virginia (1993 on)	
REASON(S) FOR WANTING TO SERVE FLUVANNA COUNTY: My wife and I love living in the county. I want to do what I can to help keep Fluvanna a vibrant community.	

**PLEASE INDICATE BELOW THE SUBCOMMITTEE(S)  
ON WHICH YOU WISH TO SERVE.**

X	SUBCOMMITTEE	DESCRIPTION
X	Future Land Use-Zion Crossroads Gateway Plan Subcommittee	Subcommittee will discuss mixed-use commercial, industrial, and higher-density residential uses with well-planned transportation improvements and gateway design standards in conjunction with Louisa County.
	Rural and Historic Preservation Subcommittee	Subcommittee will work to review Rural Cluster provisions, to enhance the Rural Preservation options, and further identify Fluvanna County's historical buildings and places.

**Submit by email ([clerk@fluvannacounty.org](mailto:clerk@fluvannacounty.org)) or mail to:  
County of Fluvanna, Attention: Clerk, Board of Supervisors, PO Box 540, Palmyra, VA 22963**

In accordance with Virginia Code §2.2-3705.1, by submitting this application, it is presumed that you are providing your personal contact information to be used for communicating with the County, and unless otherwise indicated by you, your personal contact information will not be shared publicly.

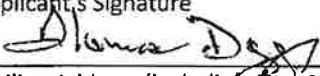
Applicant's Signature 		Date 12-17-21	
Mailing Address (including City, State, & ZIP) 947 Jefferson Drive, Palmyra, VA 22963		Physical Address (if different)	
Years Lived in Fluvanna 5 years	Phone # 757-876-4692	Alternate Phone #	Email Address wmuva@aol.com

Office Use Only			
Application Received On:	12-16-2021	Application Received By:  Caitlin Solis	
Acknowledgement Sent:	12-16-2021		
Renewal Date:		Remarks:	
Renewal Date:			
Renewal Date:			
Renewal Date:			



## APPLICATION TO SERVE ON COMPREHENSIVE PLAN SUBCOMMITTEE County of Fluvanna

Fluvanna County does not discriminate on the basis of race, color, national origin, sex, religion, age, or disability in employment or the provision of services. Before completing the application, please review the membership requirements for the Board, Commission, or Committee for which you are interested. Applicants who do not meet membership requirements will not be put forward for consideration.

Name: <b>Brittany Gray</b>	Election <input type="checkbox"/> Columbia <input type="checkbox"/> Cunningham <input type="checkbox"/> Fork Union District: <input checked="" type="checkbox"/> Palmyra <input type="checkbox"/> Rivanna <input type="checkbox"/> Other
-------------------------------	---

EXPERIENCE/PROFESSIONAL EXPERTISE/EDUCATION (Please provide dates of education and experience. You may also provide a resume/CV.):  
**Licensed Realtor for 7 years, pre-law student with Liberty University**

CURRENT OR PRIOR SERVICE ON BOARDS/COMMISSIONS/OR COMMITTEES:  
**None listed**

CIVIC ACTIVITIES AND MEMBERSHIPS (Roles with fraternal, business, church, or social groups – please provide dates):  
**None listed**

REASON(S) FOR WANTING TO SERVE FLUVANNA COUNTY:  
**A local resident of 25 years and studying land and legal development in college, I would love to use my background and passion for the law to be in a position to benefit my community.**

**PLEASE INDICATE BELOW THE SUBCOMMITTEE(S)  
ON WHICH YOU WISH TO SERVE.**

X	SUBCOMMITTEE	DESCRIPTION
X	Future Land Use-Zion Crossroads Gateway Plan Subcommittee	Subcommittee will discuss mixed-use commercial, industrial, and higher-density residential uses with well-planned transportation improvements and gateway design standards in conjunction with Louisa County.
X	Rural and Historic Preservation Subcommittee	Subcommittee will work to review Rural Cluster provisions, to enhance the Rural Preservation options, and further identify Fluvanna County's historical buildings and places.

<p><b>Submit by email (<a href="mailto:clerk@fluvannacounty.org">clerk@fluvannacounty.org</a>) or mail to:</b>  <b>County of Fluvanna, Attention: Clerk, Board of Supervisors, PO Box 540, Palmyra, VA 22963</b></p> <p>In accordance with Virginia Code §2.2-3705.1, by submitting this application, it is presumed that you are providing your personal contact information to be used for communicating with the County, and unless otherwise indicated by you, your personal contact information will not be shared publicly.</p>			
Applicant's Signature		Date	
<b>Brittany Gray (From File)</b>		<b>January 12, 2022</b>	
Mailing Address (including City, State, & ZIP)		Physical Address (if different)	
2 Watts Circle Palmyra, VA 22963			
Years Lived in Fluvanna	Phone #	Alternate Phone #	Email Address
<b>25</b>	434-906-756		BrittanyGrayattheLake@gmail.com
<b>Office Use Only</b>			
Application Received On:	01-12-2022	Application Received By: <b>Leontyne Peck</b>	
Acknowledgement Sent:	01-12-2022		
Renewal Date:		Remarks:	
Renewal Date:			
Renewal Date:			
Renewal Date:			



# APPLICATION TO SERVE ON COMPREHENSIVE PLAN SUBCOMMITTEE

## County of Fluvanna

Fluvanna County does not discriminate on the basis of race, color, national origin, sex, religion, age, or disability in employment or the provision of services. Before completing the application, please review the membership requirements for the Board, Commission, or Committee for which you are interested. Applicants who do not meet membership requirements will not be put forward for consideration.

Name: <b>Steven Hurwitz</b>	Election <input type="checkbox"/> Columbia <input type="checkbox"/> Cunningham <input type="checkbox"/> Fork Union District: <input type="checkbox"/> Palmyra <input checked="" type="checkbox"/> Rivanna <input type="checkbox"/> Other
<b>EXPERIENCE/PROFESSIONAL EXPERTISE/EDUCATION (Please provides dates of education and experience. You may also provide a resume/CV.):</b> EDUCATION BA: Rutgers University, Psychology, 1967 MA: University of Oklahoma, Industrial Management, 1975 Graduate: Air Command & Staff College - Residence, 1980 Graduate: National War College - Residence, 1987  US AIR FORCE (Highlights) 1967-1997... Base Commander: Air Force Base, Italy, 1991-1993 Commander: United Nations Command - Rear, Japan, 1987 Commander: US Air Force Squadron, Italy, 1983-1984 Inspector General Team Chief (NATO) Europe, 1984-1986 Senior Flight Examiner: Strategic Air Command Base, 1974-76  AFTER AIR FORCE CAREER Managed Homeowner Associations and Condominium Associations 1998 - 2021 Awarded PCAM (Professional Community Association Manager, 2006 Developed Curriculum and Taught Courses - Nationally for Community Associations Institute	
<b>CURRENT OR PRIOR SERVICE ON BOARDS/COMMISSIONS/OR COMMITTEES:</b> President - NATO All Ranks Club, Germany Chair - Joint Inter-Regional Study Group (Multiple Federal Agencies in Rocky Mountain Region) Member - Education Committee, Community Associations Institute (CAI), CO, Founding Member - Committee on Mountain Trade Show (CAI), Copper Mountain, CO Chair - Special Committee on Elections, Fairfax Station HOA, VA Co-Chair - Working Group, Re-Write of "Facility Management Course," (CAI) Extensive work with committees as HOA and condominium manager	
<b>CIVIC ACTIVITIES AND MEMBERSHIPS (Roles with fraternal, business, church, or social groups – please provide dates):</b> Treasurer, President - Zeta Beta Tau Fraternity, Rutgers University (NJ) 1965-1967 Treasurer - Interfraternity Council, Rutgers University, 1966-1967 Trustee - Zeta Beta Tau Fraternity, University of Colorado, 1990-1991 Trustee - Zeta Beta Tau Fraternity, University of Illinois, 1995-1996 Board Member - Camellia Symphony Orchestra, CA, 1977-1997 Member - Leadership Denver Program, 1990-1991 Member - Fluvanna Leadership Development Program, Class 16, 2017-2018	
<b>REASON(S) FOR WANTING TO SERVE FLUVANNA COUNTY:</b> To contribute to making the challenging decisions related to Fluvanna County's growth and economic development and to help maximize the outcomes from the processes leading to those decisions.	

**PLEASE INDICATE BELOW THE SUBCOMMITTEE(S)  
ON WHICH YOU WISH TO SERVE.**

X	SUBCOMMITTEE	DESCRIPTION
XX	Future Land Use-Zion Crossroads Gateway Plan Subcommittee	Subcommittee will discuss mixed-use commercial, industrial, and higher-density residential uses with well-planned transportation improvements and gateway design standards in conjunction with Louisa County.
XX	Rural and Historic Preservation Subcommittee	Subcommittee will work to review Rural Cluster provisions, to enhance the Rural Preservation options, and further identify Fluvanna County's historical buildings and places.

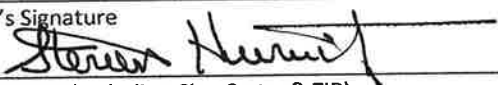
<p><b>Submit by email (<a href="mailto:clerk@fluvannacounty.org">clerk@fluvannacounty.org</a>) or mail to:</b>  <b>County of Fluvanna, Attention: Clerk, Board of Supervisors, PO Box 540, Palmyra, VA 22963</b></p> <p>In accordance with Virginia Code §2.2-3705.1, by submitting this application, it is presumed that you are providing your personal contact information to be used for communicating with the County, and unless otherwise indicated by you, your personal contact information will not be shared publicly.</p>			
Applicant's Signature 		Date <b>1-27-2022</b>	
Mailing Address (including City, State, & ZIP) 19 Vine Ridge Dr, Palmyra VA 22963		Physical Address (if different)	
Years Lived in Fluvanna <b>four</b>	Phone # 703-717-2666	Alternate Phone # 703-717-2665	Email Address <b>hurwisn@aol.com</b>
<b>Office Use Only</b>			
Application Received On:		Application Received By:	
Acknowledgement Sent:			
Renewal Date:		Remarks:	
Renewal Date:			
Renewal Date:			
Renewal Date:			



## APPLICATION TO SERVE ON COMPREHENSIVE PLAN SUBCOMMITTEE

### County of Fluvanna

Fluvanna County does not discriminate on the basis of race, color, national origin, sex, religion, age, or disability in employment or the provision of services. Before completing the application, please review the membership requirements for the Board, Commission, or Committee for which you are interested. Applicants who do not meet membership requirements will not be put forward for consideration.

Name: <b>Overton McGehee</b>	Election <input type="checkbox"/> Columbia <input type="checkbox"/> Cunningham <input checked="" type="checkbox"/> Fork Union District: <input type="checkbox"/> Palmyra <input type="checkbox"/> Rivanna <input type="checkbox"/> Other
<p>EXPERIENCE/PROFESSIONAL EXPERTISE/EDUCATION (Please provides dates of education and experience. You may also provide a resume/CV.):</p> <p>Executive Director of Habitat for Humanity Virginia 2008-present (We advise and support the 41 Habitat for Humanity Chapters in Virginia)</p> <p>Former Executive Director of Habitat for Humanity of Greater Charlottesville 1997-2008</p> <p>Former reporter for the Richmond Times-Dispatch 1982-1992</p> <p>Former reporter for the Charlottesville Daily Progress 1980-1982</p> <p>Fluvanna County High School class of 1976</p> <p>When I was with Charlottesville Habitat, we developed mixed income neighborhoods and were the first Habitat affiliate in the U.S. to buy mobile home parks to prevent displacement and to develop them to higher density mixed income neighborhoods that include affordable housing for the mobile home park residents.</p> <p>I recieved a neighborhood planning award from the American Institute of Architects Central Virginia Chapter</p> <p>I have been through the subdivision process for housing developments in five counties and one city and have advised local Habitat affiliates on housing developments on other parts of the Commonwealth. We own a farm near Kents Store and small tracts of timberland near Columbia, Carysbrook, and Shores, We have put some land in conservation easement. We also developed a seven-lot subdivision with large lots in Fluvanna.</p>	
<p>CURRENT OR PRIOR SERVICE ON BOARDS/COMMISSIONS/OR COMMITTEES:</p> <p>Board member of Housing Forward Virginia</p> <p>Founder and board member of the Virginia Statewide Community Land Trust</p> <p>Founder of the Virginia Affordable Housing Loan Fund</p> <p>Former Board member of the Virginia Housing Alliance</p> <p>Member of the legislative committee of the Virginia Housing Alliance</p> <p>Former Board member of Rural Housing Inc.</p> <p>New member of the Fluvanna County Ag Forest District advisory committee</p>	
<p>CIVIC ACTIVITIES AND MEMBERSHIPS (Roles with fraternal, business, church, or social groups – please provide dates):</p> <p>Member of First United Methodist Church and former member of Palmyra United Methodist Church</p> <p>Volunteer for Fluvanna County Historical Society</p> <p>Volunteer for Tadpole Land &amp; Trail Conservancy</p> <p>Former Member of Fluvanna Friends of Rural Preservation</p> <p>Former chair of the Fluvanna County High School Parents' advisory committee</p> <p>Former volunteer fire fighter</p>	
<p>REASON(S) FOR WANTING TO SERVE FLUVANNA COUNTY:</p> <p>I have worked with zoning and subdivision rules in several counties. Fluvanna County has a strong board and good leadership, but but it makes me sad that my own county still has the loosest, least environmentally conscious subdivision rules of any county I have encountered. Our current ordinances will allow extremely dense cluster subdivisions, even in the areas of the county designated as rural preservation areas. These dense cluster subdivisions without public water and sewer are not environmenally sustainable because the wells and drainfields are clustered too close together. And they are not rural and do not belong in the rural preservation area. We need ordinances that will follow good planning principles, that will not allow dense housing without public water and sewer, and that will keep part of Fluvanna rural. The place for dense development is close to jobs and public transportation. We also need to have overlays on Zion Crossroads and other growth areas that will encourage job growth and discourage more residential development. We are out of balance. We have allowed rapid residential growth that is out of propotion with our slow business and jobs growth. We have superb schools, but continued residential growth without business growth will impoverish the county coffers and harm our school system. I would like to serve on both subcommittees. If I cannot serve on both, I would like to serve on the rural and historic preservation subcommittee.</p> <p>I want to mention one more thing. In the 1960s, Fluvanna was unprepared for growth. We did not even require street, water, and sewer completion bonds for the first phases of Lake Monticello. If Faulconer Construction had not stepped in when the original developers went broke, the first phases would have been a disaster. My father was among those who lobbied for better ordinances then. My parents were also involved in the effort to get the Rivanna designated as Virginia's first state scenic river. As a county, we have made some progress since then, in our schools and other services, but we need better zoning and planning ordinances if we are going to be the best county we can be.</p>	



**PLEASE INDICATE BELOW THE SUBCOMMITTEE(S)  
ON WHICH YOU WISH TO SERVE.**

X	SUBCOMMITTEE	DESCRIPTION
X	Future Land Use-Zion Crossroads Gateway Plan Subcommittee	Subcommittee will discuss mixed-use commercial, industrial, and higher-density residential uses with well-planned transportation improvements and gateway design standards in conjunction with Louisa County.
X	Rural and Historic Preservation Subcommittee	Subcommittee will work to review Rural Cluster provisions, to enhance the Rural Preservation options, and further identify Fluvanna County's historical buildings and places.

<p><b>Submit by email (<a href="mailto:clerk@fluvannacounty.org">clerk@fluvannacounty.org</a>) or mail to:</b>  <b>County of Fluvanna, Attention: Clerk, Board of Supervisors, PO Box 540, Palmyra, VA 22963</b></p> <p>In accordance with Virginia Code §2.2-3705.1, by submitting this application, it is presumed that you are providing your personal contact information to be used for communicating with the County, and unless otherwise indicated by you, your personal contact information will not be shared publicly.</p>			
Applicant's Signature		Date	
		<b>10-29-2021</b>	
Mailing Address (including City, State, & ZIP)		Physical Address (if different)	
<small>924 Courthouse Rd Palmyra Va 22963</small>			
Years Lived in Fluvanna	Phone #	Alternate Phone #	Email Address
1958-1976, 2000-present	804 929-8436		omcgehee@habitatvirginia.org
<b>Office Use Only</b>			
Application Received On:	10/29/2021	Application Received By:  Caitlin Solis	
Acknowledgement Sent:	11/10/2021		
Renewal Date:		Remarks:	
Renewal Date:			
Renewal Date:			
Renewal Date:			



## APPLICATION TO SERVE ON COMPREHENSIVE PLAN SUBCOMMITTEE County of Fluvanna

Fluvanna County does not discriminate on the basis of race, color, national origin, sex, religion, age, or disability in employment or the provision of services. Before completing the application, please review the membership requirements for the Board, Commission, or Committee for which you are interested. Applicants who do not meet membership requirements will not be put forward for consideration.

Name: <b>Judith Mickelson</b>	Election <input type="checkbox"/> Columbia <input type="checkbox"/> Cunningham <input type="checkbox"/> Fork Union District: <input checked="" type="checkbox"/> Palmyra <input type="checkbox"/> Rivanna <input type="checkbox"/> Other
EXPERIENCE/PROFESSIONAL EXPERTISE/EDUCATION (Please provides dates of education and experience. You may also provide a resume/CV.): Retired Executive director of The Fluvana historical society, Palmyra. 2005 through 2015, treasurer and board member of the Fluvanna historical society., current . Board member of the Charlottesville Preservation piedmont Society. Member of same as well as member of center for Palladian Studies in America. 15 years in corporate work in Washington ,DC., GalleryDirector in DC , Studio potter and principal and teacher in private childrens pottery school. Public high school Spanish teacher in Washington DC and suburban MD. BA George Washington University, DC, graduate classes , GWU and Catholic University, DC	
CURRENT OR PRIOR SERVICE ON BOARDS/COMMISSIONS/OR COMMITTEES: Fluvanna Historical society, 2005 to present, Exec Dir., museum Director, Treasurer. Preservation piedmont board Charlottesville Various consulting engagements with groups for archival and museum and building preservati8n	
CIVIC ACTIVITIES AND MEMBERSHIPS (Roles with fraternal, business, church, or social groups – please provide dates):	
REASON(S) FOR WANTING TO SERVE FLUVANNA COUNTY: I feel very strongly about Fluvana County s future and present, particularly around our extensive and valued history in the state. In order to help in preservation and conservation of buildings, ideas, and artifacts, I would very much like to be on the preservation committee. I feel I have all the capabilities and experience and qualifications to meet the needs of this committee	

**PLEASE INDICATE BELOW THE SUBCOMMITTEE(S)  
ON WHICH YOU WISH TO SERVE.**

X	SUBCOMMITTEE	DESCRIPTION
	Future Land Use-Zion Crossroads Gateway Plan Subcommittee	Subcommittee will discuss mixed-use commercial, industrial, and higher-density residential uses with well-planned transportation improvements and gateway design standards in conjunction with Louisa County.
X	Rural and Historic Preservation Subcommittee	Subcommittee will work to review Rural Cluster provisions, to enhance the Rural Preservation options, and further identify Fluvanna County's historical buildings and places.

<p><b>Submit by email (<a href="mailto:clerk@fluvannacounty.org">clerk@fluvannacounty.org</a>) or mail to:</b>  <b>County of Fluvanna, Attention: Clerk, Board of Supervisors, PO Box 540, Palmyra, VA 22963</b></p> <p>In accordance with Virginia Code §2.2-3705.1, by submitting this application, it is presumed that you are providing your personal contact information to be used for communicating with the County, and unless otherwise indicated by you, your personal contact information will not be shared publicly.</p>			
Applicant's Signature		Date	
<b>Judith Mickelson</b>		<b>12-14-2021</b>	
Mailing Address (including City, State, & ZIP)		Physical Address (if different)	
P.O. Box 503 Palmyra, VA 22963		<small>33 Main Street, Palmyra, VA 22963</small>	
Years Lived in Fluvanna	Phone #	Alternate Phone #	Email Address
<b>21</b>	434-589-5572	<b>202-550-7020</b>	<b>Judemickel@aol.com</b>
<b>Office Use Only</b>			
Application Received On:	<b>12-14-2021</b>	Application Received By: Leontyne Peck	
Acknowledgement Sent:	<b>12-14-2021</b>		
Renewal Date:		Remarks:	
Renewal Date:			
Renewal Date:			
Renewal Date:			



## APPLICATION TO SERVE ON COMPREHENSIVE PLAN SUBCOMMITTEE

### County of Fluvanna

Fluvanna County does not discriminate on the basis of race, color, national origin, sex, religion, age, or disability in employment or the provision of services. Before completing the application, please review the membership requirements for the Board, Commission, or Committee for which you are interested. Applicants who do not meet membership requirements will not be put forward for consideration.

Name:	Election	<input type="checkbox"/> Columbia	<input type="checkbox"/> Cunningham	<input checked="" type="checkbox"/> Fork Union
<b>Kathleen Swenson Miller</b>	District:	<input type="checkbox"/> Palmyra	<input type="checkbox"/> Rivanna	<input type="checkbox"/> Other

EXPERIENCE/PROFESSIONAL EXPERTISE/EDUCATION (Please provides dates of education and experience. You may also provide a resume/CV.):

Education: BS - University of Minnesota (1970); MS - Boston University (1974); PhD - Temple Univesity (2002)

\*Experience: worked in San Diego, CA; London, England; Chapel Hill, NC; Baltimore, MD; Philadelphia, PA. Work in capacities as: pediatric occupational therapist; mental health occupational therapist; state-wide consultant as part of a university interdisciplinary faculty team at Univ. of No. Carolina that provided diagnostic work & consultation regarding children at risk and identified special needs; developed 1st early intervention program in Maryland; administered BS to MS occupational therapy program at Thomas Jefferson Univ/ Philadelphia; faculty member in occupational therapy and public health at Thomas Jefferson University.

\*Years of program development and evaluation, policy development at local/state/national levels (PhD focus was on community program development and evaluation processes).

\*Grant reviewer: U.S. Depart of Health & Human Services

\*Lead on multiple federal grants regarding preparation of national workforce to acquire e-technology skills to work with underserved populations, academic/clinical services collaboration in adoption of evidence based practice.

If you would like specific dates, my 13 page curriculum vitae is available for review.

CURRENT OR PRIOR SERVICE ON BOARDS/COMMISSIONS/OR COMMITTEES:

CIVIC ACTIVITIES AND MEMBERSHIPS (Roles with fraternal, business, church, or social groups – please provide dates):

Fluvanna Leadership Development Program: Steering Committee (2011-2021); Executive Committee & Treasurer (2012-2018); Program Evaluator (2020-21)

Martha Jefferson Patient Family Advisory Committee: 2018-2021

Wilmington Club Board: 2014 - 2017

Wednesday Music Club: 2018-2021

Fluvanna Historical Society: 2010-2021

REASON(S) FOR WANTING TO SERVE FLUVANNA COUNTY:

I live in the Rural Preservation area of Fluvanna, owning 13 acres of land with my husband. I was one of the neighbors who was strongly against the proposed Ballinger Bluff Development off of Courthouse Rd. This proposed cluster development was just wrong for the geography of the land that has a history of water & well problems in the area. I would like to be part of the solution of SMART growth in the county, impacting revision of the Comprehensive Plan and accompanying ordinances that encourage growth in the Community Planning Areas. The current Comprehensive Plan calls for 70% of growth to occur in the Community Planning Areas, 20% in rural residential and 10% in rural preservation. From 2015-2017 (the last available publicly available data), 13% of growth occurred in Community Planning Areas, 29% in Rural Residential Areas, and 60% in Rural Preservation Areas. I would like to be part of the solution to facilitate growth in the county to be aligned with the vision of the county as expressed in the Comprehensive Plan.

**PLEASE INDICATE BELOW THE SUBCOMMITTEE(S)  
ON WHICH YOU WISH TO SERVE.**

X	SUBCOMMITTEE	DESCRIPTION
	Future Land Use-Zion Crossroads Gateway Plan Subcommittee	Subcommittee will discuss mixed-use commercial, industrial, and higher-density residential uses with well-planned transportation improvements and gateway design standards in conjunction with Louisa County.
X	Rural and Historic Preservation Subcommittee	Subcommittee will work to review Rural Cluster provisions, to enhance the Rural Preservation options, and further identify Fluvanna County's historical buildings and places.

<p><b>Submit by email (<a href="mailto:clerk@fluvannacounty.org">clerk@fluvannacounty.org</a>) or mail to:</b>  <b>County of Fluvanna, Attention: Clerk, Board of Supervisors, PO Box 540, Palmyra, VA 22963</b></p> <p>In accordance with Virginia Code §2.2-3705.1, by submitting this application, it is presumed that you are providing your personal contact information to be used for communicating with the County, and unless otherwise indicated by you, your personal contact information will not be shared publicly.</p>			
Applicant's Signature		Date	
<b>Kathleen Swenson Miller</b>		<b>11/1/21</b>	
Mailing Address (including City, State, & ZIP)		Physical Address (if different)	
94 Fairview Lane, Palmyra, VA, 22963			
Years Lived in Fluvanna	Phone #	Alternate Phone #	Email Address
<b>11</b>	434.589.5399		swenson.miller@gmail.com
<b>Office Use Only</b>			
Application Received On:	11/01/2021	Application Received By: Caitlin Solis	
Acknowledgement Sent:	11/10/2021		
Renewal Date:		Remarks:	
Renewal Date:			
Renewal Date:			
Renewal Date:			



## APPLICATION TO SERVE ON COMPREHENSIVE PLAN SUBCOMMITTEE County of Fluvanna

Fluvanna County does not discriminate on the basis of race, color, national origin, sex, religion, age, or disability in employment or the provision of services. Before completing the application, please review the membership requirements for the Board, Commission, or Committee for which you are interested. Applicants who do not meet membership requirements will not be put forward for consideration.

Name: Sandra Forstbauer (Suzy) Morris	Election <input type="checkbox"/> Columbia <input checked="" type="checkbox"/> Cunningham <input type="checkbox"/> Fork Union District: <input type="checkbox"/> Palmyra <input type="checkbox"/> Rivanna <input type="checkbox"/> Other
EXPERIENCE/PROFESSIONAL EXPERTISE/EDUCATION (Please provide dates of education and experience. You may also provide a resume/CV.):  attached	
CURRENT OR PRIOR SERVICE ON BOARDS/COMMISSIONS/OR COMMITTEES:  attached	
CIVIC ACTIVITIES AND MEMBERSHIPS (Roles with fraternal, business, church, or social groups – please provide dates):  attached	
REASON(S) FOR WANTING TO SERVE FLUVANNA COUNTY:  attached	

**PLEASE INDICATE BELOW THE SUBCOMMITTEE(S)  
ON WHICH YOU WISH TO SERVE.**

X	SUBCOMMITTEE	DESCRIPTION
X	Future Land Use-Zion Crossroads Gateway Plan Subcommittee	Subcommittee will discuss mixed-use commercial, industrial, and higher-density residential uses with well-planned transportation improvements and gateway design standards in conjunction with Louisa County.
X <i>both</i>	Rural and Historic Preservation Subcommittee	Subcommittee will work to review Rural Cluster provisions, to enhance the Rural Preservation options, and further identify Fluvanna County's historical buildings and places.

**Submit by email ([clerk@fluvannacounty.org](mailto:clerk@fluvannacounty.org)) or mail to:**

**County of Fluvanna, Attention: Clerk, Board of Supervisors, PO Box 540, Palmyra, VA 22963**

In accordance with Virginia Code §2.2-3705.1, by submitting this application, it is presumed that you are providing your personal contact information to be used for communicating with the County, and unless otherwise indicated by you, your personal contact information will not be shared publicly.

Applicant's Signature <i>Sandra (Duffy) Morris</i>		Date <i>12/30/2021</i>	
Mailing Address (including City, State, & ZIP) <i>6840 Thomas Jefferson Pkwy Palmyra, Va. 22963</i>		Physical Address (if different) _____	
Years Lived in Fluvanna <i>79</i>	Phone # <i>434-589-8422</i>	Alternate Phone # <i>none</i>	Email Address <i>rkmorris42@yahoo.com</i>

**Office Use Only**

Application Received On:	<i>12/30/2021</i>	Application Received By: <i>Kelly Harris</i>
Acknowledgement Sent:		
Renewal Date:		Remarks:
Renewal Date:		
Renewal Date:		
Renewal Date:		

**SANDRA FORSTBAUER MORRIS**

Quaint Lea Farm  
6840 Thomas Jefferson Pkwy  
Palmyra, Virginia 22963

---

**EDUCATION**

10 year Postgraduate Professional License 7/1/2019 - 6/30/2029  
Child abuse recognition and intervention  
Emergency first aid, CPR and AED training  
Dyslexia awareness training

---

- 1970 - 2019 University of Virginia, Virginia Commonwealth University (courses, seminars, and institutes which update materials, methods, and information; and which add endorsements in biology, Director of Instruction, General Supervisor, and Secondary Supervisor) Spanish PREK-12  
French PREK-12
- 1969 University of Virginia, M.Ed. in the Teaching of Spanish  
Charlottesville, Virginia
- 1965 College of William & Mary, B.A. Modern Foreign Languages (Spanish & French)  
Williamsburg, Virginia
- 

Foundation for Teaching Economics - Environment and the  
Economy 2008

Principals' Institute - Longwood 2001

Commonwealth of Va. Office of Emergency Medical Services  
"Mass Casualty Incident Management Module 1 2004

VMFA - multiple summer institutes and classes

CPR AED certification 2015 - 2017

CPR AED certification 2017 - 2019

---



## PROFESSIONAL EXPERIENCE

- 1993 - 1996 Transportation/Foreign Language Facilitator, Fluvanna County Public Schools  
*SOL facilitator, Spanish teacher*
- 1976 - 2019 Teacher in Fluvanna County High School, Palmyra, Virginia. Subjects taught include Spanish levels I-V, earth science, and reading remediation, *foreign language exploratory, biology, life science, astronomy and ecology.*
- 1966 - 1976 Teacher in Fluvanna County High School, Carysbrook, Virginia. Subjects taught include biology and Spanish levels I-III.
- 1965 - 1966 Teacher at Columbia District Elementary School, Palmyra, Virginia. Taught all subjects to grades 4 and 5 in a self-contained classroom.
- 1964 - 1965 Student teacher at James Blair High School, James City County.
- 1963 - 1964 House President of Ludwell Apartments at the College of William & Mary, Williamsburg, Virginia.

## LEADERSHIP & SERVICE

### BOARDS/COMMISSIONS/COMMITTEES/MEMBERSHIPS/ CIVIC ACTIVITIES

~~1970-1972~~ Human Relations Council for Fluvanna County Schools - designated teacher representative

Project High - One of original six team members--to prepare lifelong learners

Parent Advisory Board

Virginia State 4-H Horse Show - State staff member

Fluvanna Co. Farm Bureau BOD 1991-1994 and member to present

Host Family - 4-H International Exchange Program, 1983

4-H Club - Adult leader

Coordinator for free lunches and free textbooks

Peer Tutoring Program

Visiting Committee at Gretna Junior High School, Gretna, Virginia - Chairperson

Self-Study - Fluvanna County High School

1967-68 Foreign Languages and Science Committee - Member

1978-79 Foreign Languages - Chairperson  
Curriculum Committee - Member

1991-1992 Foreign Languages and School and Community Committee Chairperson

# LEADERSHIP/SERVICE/BOARDS/COMMISSIONS/ COMMITTEES/MEMBERSHIPS/ CIVIC ACTIVITIES

Foreign Language Curriculum Guide - Chairperson

Curriculum Study Committee - Member

Textbook Selection Committees

Foreign Languages - Chairperson

Science - Committee member

Foreign Languages Department Head 1966-1990<sup>+</sup>

Annual Foreign Language - International Dinner and Entertainment - Originator, coordinator, and hostess.  
*600+ attendees*

Annual Foreign Language trips to Washington, D.C. - Originator, coordinator, guide, and lecturer.  
*6 commercial buses*

Open Door Student Exchange - School contact person, 1970-2010

Global Awareness Day - School contact person.

After School Detention Coordinator, 1986<sup>+</sup>

Foresee (gifted) Programs - Volunteer resource person and guest presenter.

Reading Remediation - Instructor

Foreign Languages Six Year Plan Committee - Chairperson and writer

---

Preparation of Annual Budget for Foreign Languages Department - Coordinator  
*State Selection Commi Hee - Governor's Spanish Academy*  
Student Teacher Program with University of Virginia - Supervising Teacher

Annual School Plan Committee - Member

School Calendar Committee - Member

Science Ace Coach

Senior class, graduation committee, prom committee, yearbook, newspaper, interpretative dance, senior play, Miss Fluvanna, band boosters, Foreign Language Club, freshman class, and senior trip - Sponsor, coordinator, or director.

---

## Leadership, service, civic activities, memberships —

Fluvanna Education Association - Secretary-treasurer, and faculty representative

Virginia Education Association life member—delegate multiple times through 2015

National Education Association life member

Sigma Delta Pi - Spanish

Kappa Delta Pi

Modern Language Association of Virginia

American Council of Teachers of Foreign Language

---

## Fluvanna Historical Society — life member

Annual Virginia State Foreign Language Conference  
Presenter - 1990 "Celebrating Foreign Languages in Our Schools."

Spanish Institute - University of Virginia.

Virginia Commonwealth University Seminar

Virginia Grant for the Humanities (One of twenty selected teachers)

National Endowment for the Humanities - UVA Institute, 1992 (One of twenty selected nationally)

1988 - Governor's Spanish Academy - Visiting teacher representing selected teachers of advanced level Spanish.

1990 - Commonwealth of Virginia Seminar on Europe College of William and Mary - County teacher representative

Mastery Teaching Training - Madeline Hunter

Cooperative Learning - Susan Kovalik and Ann Ross

Integrated Thematic Instruction - Susan Kovalik and Ann Ross

---

Leadership, service, civic activities, memberships

Fluvanna Heritage Forum 1999 - one of 200 participants

FLDP 2003-2004 first class

FLDP 2016-2017 Class 14 - Leadership class spokesperson  
April 10, 2017

FLDP Steering Committee 2017-2021

FLAG - ? to present

FLDP - Class 14 project - art, artisan, wine trail -  
continued work - contacts with Sherril Smith  
Executive Director of Artisans Center of Va, -  
met in Appomattox, Va, May 2017.  
Worked to resolve SLP issue for small  
studios (\$800) 10/17, 2018

FSPCA Board of Directors 2015 - present

Fluvanna Art Association 2018, 2019

Fluvanna Co's Animal Response Team Plan - 2014

Enhancing Equity Task Force FCPS 2020 - present

Standards of Quality Comprehensive Plan Committee  
FCPS 2014 - 2015

FCPS Springboard 2014, 2015

Project Wild - environmental responsibility 2016

## Reasons for wanting input into the Comprehensive Plan:

I love our unique Fluvanna County which still exhibits the rural character and quality of life valued by both natives and those who have come here. At 79, I span the ages, have seen many changes, traveled, always returned home to Fluvanna, worked with the public as an educator here for 54 years, kept informed of major county issues, interacted with diverse members of our population, run for BOS in 1999, viewed the build out of Lake Monticello next to our working farm, watched the JRWA at work, seen the additions to Pleasant Grove, continued to work for a wine/art/artisan trail, enjoyed painting and writing about Fluvanna "things" - I'm proud to be one of the native Fluvannians left and will always be a Fluco! I care about people and, therefore, have an obligation to advocate for a long range future plan with adequate compatible businesses and infrastructure for the place we, the people, live. Without a positive plan, there could be failure to preserve the Fluvanna we all love. The Comprehensive Plan is an absolute necessity as it is a guide to the future growth and <sup>planned</sup> development of this county and should reflect public input. I want to help plan for the future.

needs of the county and its citizens in a way which ensured that generations to come can still share a natural environment and quality of life from which we all benefit.

Sandra J. (Suzzy) Morris

**PERSONAL INTERESTS**

People  
Learning  
Challenges  
Art and artists  
Gardening  
Fishing  
Nature  
Environment  
Languages  
Diverse Cultures

Painting and drawing  
Cattle and horses  
Farming  
Science  
Social Studies  
Current events  
International affairs  
Communication  
Old homes and antiques  
writing - environment,  
nature, animals I have  
known



## APPLICATION TO SERVE ON COMPREHENSIVE PLAN SUBCOMMITTEE County of Fluvanna

Fluvanna County does not discriminate on the basis of race, color, national origin, sex, religion, age, or disability in employment or the provision of services. Before completing the application, please review the membership requirements for the Board, Commission, or Committee for which you are interested. Applicants who do not meet membership requirements will not be put forward for consideration.

Name: <b>Marvin Moss</b>	Election <input checked="" type="checkbox"/> Columbia <input type="checkbox"/> Cunningham <input type="checkbox"/> Fork Union District: <input type="checkbox"/> Palmyra <input type="checkbox"/> Rivanna <input type="checkbox"/> Other
EXPERIENCE/PROFESSIONAL EXPERTISE/EDUCATION (Please provides dates of education and experience. You may also provide a resume/CV.): I've attached my CV. I served 5 years on the BOS and chaired it for 2 years. I was a founder of the Fluvanna Heritage Trail Foundation and served as its president for 19 years. I have been president of the Fluvanna Historical Society since 2002 and former chair and present member of the Rivanna River Basin Commission	
CURRENT OR PRIOR SERVICE ON BOARDS/COMMISSIONS/OR COMMITTEES: Chaired the Environment Committee in preparation for the 2000 Fluvanna Comprehensive Plan.	
CIVIC ACTIVITIES AND MEMBERSHIPS (Roles with fraternal, business, church, or social groups – please provide dates): See my CV.	
REASON(S) FOR WANTING TO SERVE FLUVANNA COUNTY: I know the Comprehensive Plan is the blueprint for the future of this growing county, and I want very much to be involved in its creation.	

**PLEASE INDICATE BELOW THE SUBCOMMITTEE(S)  
ON WHICH YOU WISH TO SERVE.**

<b>X</b>	<b>SUBCOMMITTEE</b>	<b>DESCRIPTION</b>
X	Future Land Use-Zion Crossroads Gateway Plan Subcommittee	Subcommittee will discuss mixed-use commercial, industrial, and higher-density residential uses with well-planned transportation improvements and gateway design standards in conjunction with Louisa County.
X	Rural and Historic Preservation Subcommittee	Subcommittee will work to review Rural Cluster provisions, to enhance the Rural Preservation options, and further identify Fluvanna County's historical buildings and places.

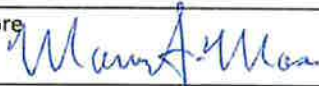
<p><b>Submit by email (<a href="mailto:clerk@fluvannacounty.org">clerk@fluvannacounty.org</a>) or mail to:</b>  <b>County of Fluvanna, Attention: Clerk, Board of Supervisors, PO Box 540, Palmyra, VA 22963</b></p> <p>In accordance with Virginia Code §2.2-3705.1, by submitting this application, it is presumed that you are providing your personal contact information to be used for communicating with the County, and unless otherwise indicated by you, your personal contact information will not be shared publicly.</p>			
Applicant's Signature 		Date <b>11/23/21</b>	
Mailing Address (including City, State, & ZIP) PO Box 394, Palmyra VA 22963		Physical Address (if different) <small>14054 James Madison Hwy, Palmyra VA 22963</small>	
Years Lived in Fluvanna <b>26</b>	Phone # 434-906-6168	Alternate Phone #	Email Address mross8@centurylink.net
<b>Office Use Only</b>			
Application Received On:		Application Received By:	
Acknowledgement Sent:			
Renewal Date:		Remarks:	
Renewal Date:			
Renewal Date:			
Renewal Date:			



**Marvin F. Moss**

**Glen Burnie Farm**

**PO Box 394**

**Palmyra, VA 22963**

**Curriculum Vitae**

**Professional Experience**

**Chief of Staff, Senator Paul S. Sarbanes (D,MD) 1977-1995**  
**Directed all of the senator's legislative and political activities**  
**including coordination with his principal committees**

**Legislative Director, Congressman Goodloe E. Byron (D,MD)**  
**1971-1976**

**United States Army 1959-1969** Left the Army after 10 ½ years of  
service after obtaining the rank of Major. Served in Germany,  
Rhodesia/Zimbabwe, Ethiopia and Vietnam. Military Intelligence  
briefing officer for Secretary of Defense Robert McNamara  
during the June 1967 Middle East War. Served with 101<sup>st</sup>  
Airmobile Division in Vietnam 1968-1969. Decorations include  
the Bronze Star, Joint Service Commendation Medal and Army  
Commendation Medal.

**Community and Other Experience**

**Two Presidential appointments by President William J. Clinton to**  
**represent the Executive Branch on the National Historical Publications**  
**and Records Commission at the National Archives, the Archives' only**  
**grant-making organization. Chaired its Executive Committee for two**  
**years. 1995-2002**

**Appointed by Governors Warner and Kaine to the Capital Square**  
**Preservation Council overseeing the restoration of Virginia's historic**  
**Capitol and its grounds 1999-2004**

**Staff Director of a major study of the United States Naval Academy in Annapolis. Chaired by Admiral Stansfield Turner and Dr. Judy Mohraz, President of Goucher College. The study's report The Higher Standard - Assessing the U.S. Naval Academy led to major changes at the Academy and many of its recommendations were subsequently implemented. 1997**

**Lectured on US foreign policy and domestic politics at Ball State University, the US Naval Academy and Salisbury State University 1995-1997**

**Member and Former Chair, Rivanna River Basin Commission**

**Former Member and Chair, Fluvanna County Board of Supervisors**

**President, Fluvanna Historical Society**

**Former President, Fluvanna Heritage Trail Foundation**

**Named Virginia's "Unsung Hero" in 2016**

**Benefactor of a small Eastern Orthodox Monastery, The Skete of St. Maximos the Confessor, in Palmyra, VA**

### **Education**

**BS US Military Academy at West Point 1959**

**MA International Relations, The American University, Washington, DC after studies at University/College of Rhodesia Nyasaland 1965**



## APPLICATION TO SERVE ON COMPREHENSIVE PLAN SUBCOMMITTEE County of Fluvanna

Fluvanna County does not discriminate on the basis of race, color, national origin, sex, religion, age, or disability in employment or the provision of services. Before completing the application, please review the membership requirements for the Board, Commission, or Committee for which you are interested. Applicants who do not meet membership requirements will not be put forward for consideration.

Name: <b>Deborah D. Murdock</b>	Election <input checked="" type="checkbox"/> Columbia <input type="checkbox"/> Cunningham <input type="checkbox"/> Fork Union District: <input type="checkbox"/> Palmyra <input type="checkbox"/> Rivanna <input type="checkbox"/> Other
EXPERIENCE/PROFESSIONAL EXPERTISE/EDUCATION (Please provide dates of education and experience. You may also provide a resume/CV.): Studied Art History at Vassar College 1961-2; 1975 - 1977 planning and Architectural History at University of Virginia  1972 - 1976 Employed by the Virginia Department of Historic Resources to document and survey historic buildings in Fluvanna County and parts of Cumberland, Buckingham and Albemarle counties.	
CURRENT OR PRIOR SERVICE ON BOARDS/COMMISSIONS/OR COMMITTEES: 1992, Zoning Ordinances Committee, Fluvanna County. Chair, Comprehensive Planning Committee on Historic Preservation, 1999 President of Preservation Piedmont 1996-7 Member of Board of Directors Preservation Virginia, Thomas Jefferson Branch 1992-2006 Board of Equalization 1994 to 2007 New Courthouse Location Committee, 1997 Fluvanna County Ag/Forestral Commission, 1999 to present	
CIVIC ACTIVITIES AND MEMBERSHIPS (Roles with fraternal, business, church, or social groups – please provide dates): Fluvanna County Historical Society, Vice President, since 1980.	
REASON(S) FOR WANTING TO SERVE FLUVANNA COUNTY: This is my community in which I have lived since 1972 and in which my son and his family live. I care about its future.	

**PLEASE INDICATE BELOW THE SUBCOMMITTEE(S)  
ON WHICH YOU WISH TO SERVE.**

X	SUBCOMMITTEE	DESCRIPTION
	Future Land Use-Zion Crossroads Gateway Plan Subcommittee	Subcommittee will discuss mixed-use commercial, industrial, and higher-density residential uses with well-planned transportation improvements and gateway design standards in conjunction with Louisa County.
X	Rural and Historic Preservation Subcommittee	Subcommittee will work to review Rural Cluster provisions, to enhance the Rural Preservation options, and further identify Fluvanna County's historical buildings and places.

**Submit by email ([clerk@fluvannacounty.org](mailto:clerk@fluvannacounty.org)) or mail to:**  
**County of Fluvanna, Attention: Clerk, Board of Supervisors, PO Box 540, Palmyra, VA 22963**

In accordance with Virginia Code §2.2-3705.1, by submitting this application, it is presumed that you are providing your personal contact information to be used for communicating with the County, and unless otherwise indicated by you, your personal contact information will not be shared publicly.

Applicant's Signature <i>Ruborah D. Murdock</i>		Date <b>November 22, 2021</b>	
Mailing Address (including City, State, & ZIP) P.O Box 65, Kents Store, Va. 23084		Physical Address (if different) <small>478 Laughton Lane Kents Store, Va 23084</small>	
Years Lived in Fluvanna <b>49</b>	Phone # 434-589-3083	Alternate Phone #	Email Address ddmlaughton@yahoo.com
Office Use Only			
Application Received On:		Application Received By:	
Acknowledgement Sent:			
Renewal Date:		Remarks:	
Renewal Date:			
Renewal Date:			
Renewal Date:			



## APPLICATION TO SERVE ON COMPREHENSIVE PLAN SUBCOMMITTEE County of Fluvanna

Fluvanna County does not discriminate on the basis of race, color, national origin, sex, religion, age, or disability in employment or the provision of services. Before completing the application, please review the membership requirements for the Board, Commission, or Committee for which you are interested. Applicants who do not meet membership requirements will not be put forward for consideration.

Name: <b>Charles Parrish</b>	Election <input type="checkbox"/> Columbia <input type="checkbox"/> Cunningham <input type="checkbox"/> Fork Union District: <input checked="" type="checkbox"/> Palmyra <input type="checkbox"/> Rivanna <input type="checkbox"/> Other
EXPERIENCE/PROFESSIONAL EXPERTISE/EDUCATION (Please provides dates of education and experience. You may also provide a resume/CV.): Resume Attached	
CURRENT OR PRIOR SERVICE ON BOARDS/COMMISSIONS/OR COMMITTEES: Resume Attached	
CIVIC ACTIVITIES AND MEMBERSHIPS (Roles with fraternal, business, church, or social groups – please provide dates): Resume Attached	
REASON(S) FOR WANTING TO SERVE FLUVANNA COUNTY: Reasons Attached	

**PLEASE INDICATE BELOW THE SUBCOMMITTEE(S)  
ON WHICH YOU WISH TO SERVE.**

X	SUBCOMMITTEE	DESCRIPTION
	Future Land Use-Zion Crossroads Gateway Plan Subcommittee	Subcommittee will discuss mixed-use commercial, industrial, and higher-density residential uses with well-planned transportation improvements and gateway design standards in conjunction with Louisa County.
X	Rural and Historic Preservation Subcommittee	Subcommittee will work to review Rural Cluster provisions, to enhance the Rural Preservation options, and further identify Fluvanna County's historical buildings and places.

<p><b>Submit by email (<a href="mailto:clerk@fluvannacounty.org">clerk@fluvannacounty.org</a>) or mail to:</b>  <b>County of Fluvanna, Attention: Clerk, Board of Supervisors, PO Box 540, Palmyra, VA 22963</b></p> <p>In accordance with Virginia Code §2.2-3705.1, by submitting this application, it is presumed that you are providing your personal contact information to be used for communicating with the County, and unless otherwise indicated by you, your personal contact information will not be shared publicly.</p>			
Applicant's Signature		Date	
<b>Charles H.T. Parrish</b>		<b>11-27-21</b>	
Mailing Address (including City, State, & ZIP)		Physical Address (if different)	
P.O. Box 85. Palmyra Va 22963		429 Main Street Palmyra Va 22963	
Years Lived in Fluvanna	Phone #	Alternate Phone #	Email Address
<b>25</b>	434-981-9312		<b>ceo4s@virginia.edu</b>
<b>Office Use Only</b>			
Application Received On:	<b>11/27/2021</b>	Application Received By: <b>Caitlin Solis</b>	
Acknowledgement Sent:	<b>11/29/2021</b>		
Renewal Date:		Remarks:	
Renewal Date:			
Renewal Date:			
Renewal Date:			

I was born and raised in this County, and as I am finishing out my graduate program I have never been more confident that Fluvanna is where I plan to spend the rest of my life. Every place I go in the County I hear stories about my relatives and what they have done at or said about about that place, and I am able to share in the dreams that have been passed down through my family since my first ancestor moved to this area in the 1690s, about eight decades before this beautiful land became known as Fluvanna County. As I am sure many of us who have lived here for some time can resonate with, I am not naive to aspects of the County that warrant change or could benefit from growth, but there are many obvious as well as obscure landmarks in our various Fluco Communities that deserve preservation. I believe that my connection, experience, and knowledge of the County would make me a strong addition to this subcommittee. Further, I know that there are many parts of this County and its history that I do not know, but my interest in and curiosity about other people's stories and the physical spaces that represent them will motivate me to expand my, and the County's, awareness of those histories. I have gone through and graduated from the Fluvanna Leadership Development Program twice, and each time, once as a teengager and once in my twenties, I have had the opportunity to be exposed to systems and traditions in this County that I was previously unaware of, and meet and build relationships with other passionate Fluvannians who want to better serve our County. The first time I went through the program I was preparing to leave for college, and the second time I was preparing to leave for graduate school. Now that I am almost back I want to take the knowledge and relationships I've built and put it to work for the County and our community.

It is difficult to think of anything I care more about than Fluvanna County; in addition to our history and our culture, our landscape makes this place all the more special. I Chair a new non-profit, Tadpole Land & Trail Conservancy (TLTC), that serves Central Virginia and partners with landowners who wish to preserve their land in perpetuity but do not have an heir that can help fulfill that wish. TLTC is entrusted with these individuals' properties and ensures that they are preserved through conservation easements to the landowner's standards while also opening the land to public access for greater community enjoyment based on the owner's timeline. Though our organization only began operations in 2021, we've already acquired one property here in the County that is in the planning stages to become a nature preserve with trails and picnic areas, and we are partnering with two Fluvanna farmers to preserve their family farm when the time comes. As a cattle farmer myself, I am passionate about rural preservation and ensuring that the Fluvanna I grew up with will still exist for my kids and my future students to enjoy for generations to come.

When thinking about serving Fluvanna on a Rural and Historic Preservation Subcommittee, I was reminded of a passage from David Berr's *Virginia's Palmyra*, "If Walker Timberlake toured his 'grandly idyllic Seat of Justice' today, he would immediately recognize the Court Green and delight in hearing that a Columbia University architecture professor christened it the 'Acropolis of Palmyra.' He might be surprised by the amount of planning now

required to build here, but perhaps more than some he would welcome the idea of a Comprehensive Plan to ease growing pains like the ones he experienced when he brought into being this courthouse community. He would surely notice the mark that fires, floods, neglect, politics, and seeming progress have each left on this place still called Palmyra. Yet, despite the gains and losses, the Reverend Mr. Timberlake would know from his visit that the ‘Shiretown of Fluvanna’ has held its own and was well-positioned for the present age” (2012; p. 36). Though this passage was written with Palmyra in mind, I think it speaks well to how I picture Fluvanna to be well-positioned for the future and frames why I want to contribute my passion to this cause. If I am able to serve on this subcommittee I will bring with me the same devotion, though perhaps occasionally a different perspective, as those who have sacrificed for and contributed to our County before me. As we approach two and a half centuries of this County’s existence, I want to work to preserve and share all of the histories that came before and during that time for all those that come after us.



# Charles Haden Thomas Parrish

P.O. Box 85, Palmyra Va, 22963 | +1 (434) 981-9312 | [ceo-ts@virginia.edu](mailto:ceo-ts@virginia.edu)

## EDUCATION

---

- Vanderbilt University, Peabody College – Nashville, TN** **August 2020 – Present**
- *Human Development Counseling, School Counseling Track*
  - *School Counseling Intern at Waverly Belmont Elementary School; Two Rivers Middle School*
- University of Virginia, Class of 2018 – Charlottesville, VA** **August 2014-May 2018**
- *African American and African Studies; Sociology*
- Fluvanna County Leadership Development Program – Fluvanna County, Va** **2013-2014; 2019-2020**
- *Class 11 & 17 Student* - a program to educate citizens about Fluvanna County and the issues and challenges it faces; to prepare its citizens for involvement; and to encourage their participation in keeping Fluvanna a desirable place to live and work
- Meriwether Lewis Institute for Civic Leadership – Charlottesville, Va** **January 2015 – May 2018**
- *2018 Fellow; Vice President of Student Affairs Intern*
  - A fellowship that brings together a diverse cohort of 25 students together for a two-and-a-half-year program to nourish lifelong leadership
  - Culminated in a project proposal for a “Student Space Reservation” platform that navigated inter-University politics
- Fluvanna County High School – Fluvanna County, Va** **May 2014**
- *Student Government Association member*
  - *Interact Club President*

## RELEVANT EXPERIENCE

---

- Tadpole Land & Trail Conservancy** **February 2020 – Present**
- *Chairman* - Lead and represent the Board of Directors of this nonprofit corporation in Central Virginia in achieving the Corporation’s purposes in a manner that respects the natural environment and the ecologically sound use of land and natural resources
  - Devoted to preserving and protecting natural ecosystems and wildlife habitats
  - Educate the public on issues related to the environment and protection of natural resources
  - Provide outdoor educational and recreational opportunities to the public
- Farm Bureau Board of Directors** **September 2018 - Present**
- *Scholarship Committee Chair* – set criteria for application and coordinate selection of recipients
- Office of Housing and Residential Experience, Vanderbilt University – Nashville, TN** **August 2020- Present**
- *Graduate Building Manager (Assistantship)* – supervise one of the Quarantine & Isolation dorms during the COVID-19 Pandemic the quarantined and isolated undergraduate residents and protect the broader community
  - *Graduate Area Coordinator (Assistantship)* – work with 19 Resident Advisors to oversee two Residential Colleges and support residents
- Virginia College Advising Corps – Charlottesville, VA** **July 2018 –May 2020**
- *A joint venture of The University of Virginia and the College Advising Corps and is an AmeriCorps program.*
  - *College Advisor at Fluvanna County High School*
  - *Summer Facilitator* - helped develop a 4-week intensive training program to provide 40 new and returning advisers relevant information about college advising, admissions, college entrance exams, family engagement and best practices
  - Cultivated productive working relationships with school administrators, counselors, and teachers to promote a college-going culture at Fluvanna County High School
  - Counseled one-on-one with 100% of graduating seniors and many underclassmen to find their “best match” post-secondary plans, complete applications, and discuss financial aid applications and resources
  - Presented to several classrooms of approximately 30 students as well as grade level assemblies with over 300 attendees on the importance of performing well academically, getting involved in extracurricular activities, and pursuing higher education, the military, or the workforce upon high school graduation
  - Coordinated regular visits from local college and trade school representatives and military recruiters to the high school campus to enhance the visibility of post-secondary options to students
  - Organized admissions and financial aid informational events for parents
  - Researched, distributed, and organized scholarships for students to apply to
  - Collected metrics such as submitted college applications, acceptances, scholarships, and financial-aid applications for a national external evaluation to quantitatively measure outcomes and qualitative results
  - Coordinated fieldtrips to allow students to experience college campuses across Virginia and Washington D.C.

**National Crisis Hotline – Charlottesville, Va****January 2017-May 2018**

- *Phone Crisis Counselor (volunteer)* – received 30 hours of training to speak with callers on a variety of topics and to provide a stable conversation in crisis situations – volunteered an average of 4 hours a week with occasional overnights during an academic year
- *Volunteer Trainer* – led 10-18 new volunteers through their 30-hour training semester, two semesters in a row

**Parks and Recreation Advisory Board (RAB)****December 2012 – August 2014**

- *Youth Representative*

**PROFESSIONAL DEVELOPMENT & MEMBERSHIPS**

- 
- **Chi Sigma Iota – Member** **February 2021 – Present**
    - *New Member and Wellness Chair*
    - An international honor society that values academic and professional excellence in counseling
    - Foster a strong professional identity through counseling students who contribute to the realization of a healthy society by fostering wellness and human dignity
  - **American School Counselor Association – Student Member** **August 2020- Present**
  - **Americorps - Member** **July 2018 -May 2020**
  - **Virginia College Access Network - Member** **September 2018-May 2020**
    - *2019&2020 Conference Attendee*
  - **National College Advising Corps - Member** **September 2018- May 2020**
    - *2018-2019 & 2019-2020 Summit attendee at the national level*
  - **Vanderbilt School Counselor Conference - Attendee** **April 2019**
  - **Youth Mental Health First Aid – Certification** **February 2019**

**AWARDS & HONORS**

- 
- **Superintendent’s Award for Outstanding Community Member**, Fluvanna County Public Schools **May 2019**
    - Each year, the Superintendent awards one student, teacher and community member at graduation.
  - **Madison House Volunteer of the Year**, Madison House, University of Virginia **April 2018**
    - Madison House is an umbrella organization with 22 volunteer programs and 4,296 student volunteers
  - **Superintendent’s Award for Student**, Fluvanna County Public Schools **May 2014**
    - Each year, the Superintendent awards one student, teacher, and community member at graduation.



## APPLICATION TO SERVE ON COMPREHENSIVE PLAN SUBCOMMITTEE County of Fluvanna

Fluvanna County does not discriminate on the basis of race, color, national origin, sex, religion, age, or disability in employment or the provision of services. Before completing the application, please review the membership requirements for the Board, Commission, or Committee for which you are interested. Applicants who do not meet membership requirements will not be put forward for consideration.

Name: <b>Andy Sorrell</b>	Election <input checked="" type="checkbox"/> Columbia <input type="checkbox"/> Cunningham <input type="checkbox"/> Fork Union District: <input type="checkbox"/> Palmyra <input type="checkbox"/> Rivanna <input type="checkbox"/> Other
EXPERIENCE/PROFESSIONAL EXPERTISE/EDUCATION (Please provides dates of education and experience. You may also provide a resume/CV.): decade as a va local land use planner, decade experience in rural preservation, land use and rural econmic developement.	
CURRENT OR PRIOR SERVICE ON BOARDS/COMMISSIONS/OR COMMITTEES: Chair EDTAC - former member of AG forestal Committee, former county planner	
CIVIC ACTIVITIES AND MEMBERSHIPS (Roles with fraternal, business, church, or social groups – please provide dates):	
REASON(S) FOR WANTING TO SERVE FLUVANNA COUNTY: 18 year county resident with much planning experience and background - specific to rural land use planning.	

**PLEASE INDICATE BELOW THE SUBCOMMITTEE(S)  
ON WHICH YOU WISH TO SERVE.**

X	SUBCOMMITTEE	DESCRIPTION
X	Future Land Use-Zion Crossroads Gateway Plan Subcommittee	Subcommittee will discuss mixed-use commercial, industrial, and higher-density residential uses with well-planned transportation improvements and gateway design standards in conjunction with Louisa County.
X	Rural and Historic Preservation Subcommittee	Subcommittee will work to review Rural Cluster provisions, to enhance the Rural Preservation options, and further identify Fluvanna County's historical buildings and places.

<p><b>Submit by email (<a href="mailto:clerk@fluvannacounty.org">clerk@fluvannacounty.org</a>) or mail to:</b>  <b>County of Fluvanna, Attention: Clerk, Board of Supervisors, PO Box 540, Palmyra, VA 22963</b></p> <p>In accordance with Virginia Code §2.2-3705.1, by submitting this application, it is presumed that you are providing your personal contact information to be used for communicating with the County, and unless otherwise indicated by you, your personal contact information will not be shared publicly.</p>			
Applicant's Signature		Date	
<b>Andrew V. Sorrell</b>		<b>11/17/21</b>	
Mailing Address (including City, State, & ZIP)		Physical Address (if different)	
637 Courthouse Rd.			
Years Lived in Fluvanna	Phone #	Alternate Phone #	Email Address
<b>18</b>	804-921-1235		<b>avsorrell80@gmail.com</b>
<b>Office Use Only</b>			
Application Received On:	<b>11/17/2021</b>	Application Received By: <b>Caitlin Solis</b>	
Acknowledgement Sent:	<b>11/17/2021</b>		
Renewal Date:		Remarks:	
Renewal Date:			
Renewal Date:			
Renewal Date:			



## APPLICATION TO SERVE ON COMPREHENSIVE PLAN SUBCOMMITTEE County of Fluvanna

Fluvanna County does not discriminate on the basis of race, color, national origin, sex, religion, age, or disability in employment or the provision of services. Before completing the application, please review the membership requirements for the Board, Commission, or Committee for which you are interested. Applicants who do not meet membership requirements will not be put forward for consideration.

Name: <b>Gibson Worsham</b>	Election <input checked="" type="checkbox"/> Columbia <input type="checkbox"/> Cunningham <input type="checkbox"/> Fork Union District: <input type="checkbox"/> Palmyra <input type="checkbox"/> Rivanna <input type="checkbox"/> Other
EXPERIENCE/PROFESSIONAL EXPERTISE/EDUCATION (Please provides dates of education and experience. You may also provide a resume/CV.): Education: M.A., Architectural History, University of Virginia, 1996 Bachelor of Architecture, College of Architecture, Virginia Polytechnic Institute and State University, 1977Registered Architect, Virginia- 1981 Experience: Architect, 2014-2020, Associate, 2021-present, Glave and Holmes Architecture, Project manager in charge of historic preservation projects within the Cultural Studio, including tax credit projects, additions to historic buildings, and renovation and restoration projects. Expertise in classical and traditional design principles. Director of Historic Architecture, Studio Ammons Architects, Petersburg, Virginia, 2010-2014 Managed projects ranging from cultural resource management and exhibit design, to classical residential architecture and urban planning projects. Director of Historic Architecture, 3north Architects, Richmond, Virginia, 2007-2010 Design leader for historic preservation projects including preservation planning and documentation, tax credit management, adaptive reuse design, new buildings or additions in historic districts, and other projects requiring expertise in traditional design or state or Federal historic design review approval. Principal of Gibson Worsham, Architect, Christiansburg, Virginia, 1984-2006	
CURRENT OR PRIOR SERVICE ON BOARDS/COMMISSIONS/OR COMMITTEES: Petersburg VA Architectural Review Board 2012-2018 Presidential Appointment to the National Capital Planning Commission	
CIVIC ACTIVITIES AND MEMBERSHIPS (Roles with fraternal, business, church, or social groups – please provide dates): American Institute of Architects Institute for Classical Art and Architecture	
REASON(S) FOR WANTING TO SERVE FLUVANNA COUNTY: As an architect, architectural historian and, with my wife and sons, Fluvanna County farmer, I am interested and knowledgeable in the rural character of the county and its conservation. I have executed numerous historic resource studies in Virginia and elsewhere, including Goochland County.	

**PLEASE INDICATE BELOW THE SUBCOMMITTEE(S)  
ON WHICH YOU WISH TO SERVE.**

X	SUBCOMMITTEE	DESCRIPTION
	Future Land Use-Zion Crossroads Gateway Plan Subcommittee	Subcommittee will discuss mixed-use commercial, industrial, and higher-density residential uses with well-planned transportation improvements and gateway design standards in conjunction with Louisa County.
X	Rural and Historic Preservation Subcommittee	Subcommittee will work to review Rural Cluster provisions, to enhance the Rural Preservation options, and further identify Fluvanna County's historical buildings and places.

<p><b>Submit by email (<a href="mailto:clerk@fluvannacounty.org">clerk@fluvannacounty.org</a>) or mail to:</b>  <b>County of Fluvanna, Attention: Clerk, Board of Supervisors, PO Box 540, Palmyra, VA 22963</b></p> <p>In accordance with Virginia Code §2.2-3705.1, by submitting this application, it is presumed that you are providing your personal contact information to be used for communicating with the County, and unless otherwise indicated by you, your personal contact information will not be shared publicly.</p>			
Applicant's Signature		Date	
<b>Gibson Worsham</b>		<b>12-6-2021</b>	
Mailing Address (including City, State, & ZIP) <small>3687 Venable Road, Kents Store, VA 23087</small>		Physical Address (if different)	
Years Lived in Fluvanna	Phone #	Alternate Phone #	Email Address
<b>3</b>	804-898-5852		gibson.worsham@gmail.com
<b>Office Use Only</b>			
Application Received On:	<b>12-8-2021</b>	Application Received By: Leontyne Peck	
Acknowledgement Sent:	<b>12-8-2021</b>		
Renewal Date:		Remarks:	
Renewal Date:			
Renewal Date:			
Renewal Date:			



## APPLICATION TO SERVE ON COMPREHENSIVE PLAN SUBCOMMITTEE County of Fluvanna

Fluvanna County does not discriminate on the basis of race, color, national origin, sex, religion, age, or disability in employment or the provision of services. Before completing the application, please review the membership requirements for the Board, Commission, or Committee for which you are interested. Applicants who do not meet membership requirements will not be put forward for consideration.

Name: <b>Steve Smith</b>	Election <input type="checkbox"/> Columbia <input checked="" type="checkbox"/> Cunningham <input type="checkbox"/> Fork Union District: <input type="checkbox"/> Palmyra <input type="checkbox"/> Rivanna <input type="checkbox"/> Other
EXPERIENCE/PROFESSIONAL EXPERTISE/EDUCATION (Please provide dates of education and experience. You may also provide a resume/CV.): USN Reserve 1968 - 1974 / Active Duty 1970 - 1971 Kodiak Alaska International Business Machines (IBM) 1969 - 1980 Various Admin Positions Los Angeles CA IBM 1981-1993 Cash, Bldg, Personnel, & Project Mgmt Positions, (various sites) San Francisco CA IBM Credit Corporation 1993 - 1995 Financial Portofolio Management San Ramon CA IBM HQ 1995 - 1996 Admin & Cash Mgmt Southbury CT / Stamford CT Small Business Management (Marina) 1997 - 2004 New Fairfield CT IBM (Business Partner) 2005 - 2010 Sales San Jose CA Retired to Fluvanna VA 2010	
CURRENT OR PRIOR SERVICE ON BOARDS/COMMISSIONS/OR COMMITTEES: Sun States Federal Credit Union 1972 - 1980 Credit Review & Various Committees Los Angeles CA Bentley Park Home Owners Association 2006 - 2010 President San Jose CA Lake Monticello Community Development Advisory Committee 2021 Palmyra VA	
CIVIC ACTIVITIES AND MEMBERSHIPS (Roles with fraternal, business, church, or social groups – please provide dates): Lake Monticello Water Safety Patrol 2011 - 2019 Virginia Department Wildlife Resources Certified Instructor 2012 - 2019 Fluvanna Leadership Development 2019 Palmyra VA Lake Monticello Newcomers and Old Friends 2010 - 2021 Fluvanna County Meals on Wheels 2011 - 2021 Lake Monticello Community Foundation 2021	
REASON(S) FOR WANTING TO SERVE FLUVANNA COUNTY: Fluvanna's Comprehensive Plan is extremely important to every resident. Fluvanna needs thoughtful long term planning to ensure the Past, Current, and Future visions of all of our Residents are balanced as we evolve over the next 50 years.	

**PLEASE INDICATE BELOW THE SUBCOMMITTEE(S)  
ON WHICH YOU WISH TO SERVE.**

X	SUBCOMMITTEE	DESCRIPTION
	Future Land Use-Zion Crossroads Gateway Plan Subcommittee	Subcommittee will discuss mixed-use commercial, industrial, and higher-density residential uses with well-planned transportation improvements and gateway design standards in conjunction with Louisa County.
XXX	Rural and Historic Preservation Subcommittee	Subcommittee will work to review Rural Cluster provisions, to enhance the Rural Preservation options, and further identify Fluvanna County's historical buildings and places.

**Submit by email ([clerk@fluvannacounty.org](mailto:clerk@fluvannacounty.org)) or mail to:  
County of Fluvanna, Attention: Clerk, Board of Supervisors, PO Box 540, Palmyra, VA 22963**

In accordance with Virginia Code §2.2-3705.1, by submitting this application, it is presumed that you are providing your personal contact information to be used for communicating with the County, and unless otherwise indicated by you, your personal contact information will not be shared publicly.

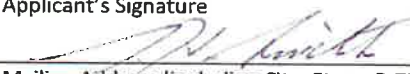
Applicant's Signature 		Date December 29, 2021	
Mailing Address (including City, State, & ZIP) 6 Sunset Ct. Palmyra, VA		Physical Address (if different)	
Years Lived in Fluvanna 11	Phone # 434 326 2007	Alternate Phone #	Email Address campsmith@hotmail.com

Office Use Only			
Application Received On:		Application Received By:	
Acknowledgement Sent:			
Renewal Date:		Remarks:	
Renewal Date:			
Renewal Date:			
Renewal Date:			





## APPLICATION TO SERVE ON COMPREHENSIVE PLAN SUBCOMMITTEE County of Fluvanna

Fluvanna County does not discriminate on the basis of race, color, national origin, sex, religion, age, or disability in employment or the provision of services. Before completing the application, please review the membership requirements for the Board, Commission, or Committee for which you are interested. Applicants who do not meet membership requirements will not be put forward for consideration.

Name: <b>Cindy L. Taylor</b>	Election <input type="checkbox"/> Columbia <input type="checkbox"/> Cunningham <input type="checkbox"/> Fork Union District: <input checked="" type="checkbox"/> Palmyra <input type="checkbox"/> Rivanna <input type="checkbox"/> Other
EXPERIENCE/PROFESSIONAL EXPERTISE/EDUCATION (Please provide dates of education and experience. You may also provide a resume/CV.):  Resident of Fluvanna County since 2018 2021 - Graduate Realtor Institute (GRI designation) 2017 - Present: Real Estate Agent, REALTOR (Licensed in West Virginia and Virginia)  2001 - 2017: West Virginia University 2015 - 2017 - Event Planner and Program Coordinator, WVU Hospital Administration / Heart & Vascular Institute 2013 - 2015 - Senior Executive Assistant, WVU Hospital Administration 2001 - 2013 - Special Events Coordinator, WVU Health Sciences  1994 - ICS School of Business / Marketing	
CURRENT OR PRIOR SERVICE ON BOARDS/COMMISSIONS/OR COMMITTEES:  Dec 2009 - Oct 2017: Treasurer, Vice President and President, Board of Directors for a 46 unit subdivision in Morgantown, WV (Pleasant Hill Subdivision)  Jan 2020-Dec 2020: Charlottesville Area Association of Realtors Master Communicatoins Group Committee Jan 2021 - Present: Charlottesville Area Association of Realtors Master Public Affairs Group Committee Upcoming: Dec 2021 - Nov 2022: Virginia Realtors Professional Development Committee	
CIVIC ACTIVITIES AND MEMBERSHIPS (Roles with fraternal, business, church, or social groups – please provide dates):  2021: Women in Business - Member 2021: Fluvanna County Chamber of Commerce - Member	
REASON(S) FOR WANTING TO SERVE FLUVANNA COUNTY:  I would like to become more involved in my community. I would be honored to participate in helping Fluvanna County continue to thrive.	

**PLEASE INDICATE BELOW THE SUBCOMMITTEE(S)  
ON WHICH YOU WISH TO SERVE.**

X	SUBCOMMITTEE	DESCRIPTION
X	Future Land Use-Zion Crossroads Gateway Plan Subcommittee	Subcommittee will discuss mixed-use commercial, industrial, and higher-density residential uses with well-planned transportation improvements and gateway design standards in conjunction with Louisa County.
	Rural and Historic Preservation Subcommittee	Subcommittee will work to review Rural Cluster provisions, to enhance the Rural Preservation options, and further identify Fluvanna County's historical buildings and places.

<p><b>Submit by email (<a href="mailto:clerk@fluvannacounty.org">clerk@fluvannacounty.org</a>) or mail to:</b>  <b>County of Fluvanna, Attention: Clerk, Board of Supervisors, PO Box 540, Palmyra, VA 22963</b></p> <p>In accordance with Virginia Code §2.2-3705.1, by submitting this application, it is presumed that you are providing your personal contact information to be used for communicating with the County, and unless otherwise indicated by you, your personal contact information will not be shared publicly.</p>			
Applicant's Signature <i>Cindy S. Taylor</i>		Date <b>11/10/2021</b>	
Mailing Address (including City, State, & ZIP) <i>1349 Georges Mill Rd, Palmyra, VA 22963</i>		Physical Address (if different)	
Years Lived in Fluvanna <b>3</b>	Phone # 434-422-2507	Alternate Phone #	Email Address cindytaylor1realtor@gmail.com
<b>Office Use Only</b>			
Application Received On:	11/10/2021	Application Received By: Caitlin Solis	
Acknowledgement Sent:	11/10/2021		
Renewal Date:		Remarks:	
Renewal Date:			
Renewal Date:			
Renewal Date:			







## PLANS APPLIED BY USER (02/01/2022 TO 02/28/2022) FOR FLUVANNA COUNTY BUILDING AND PLANNING DEPARTMENT

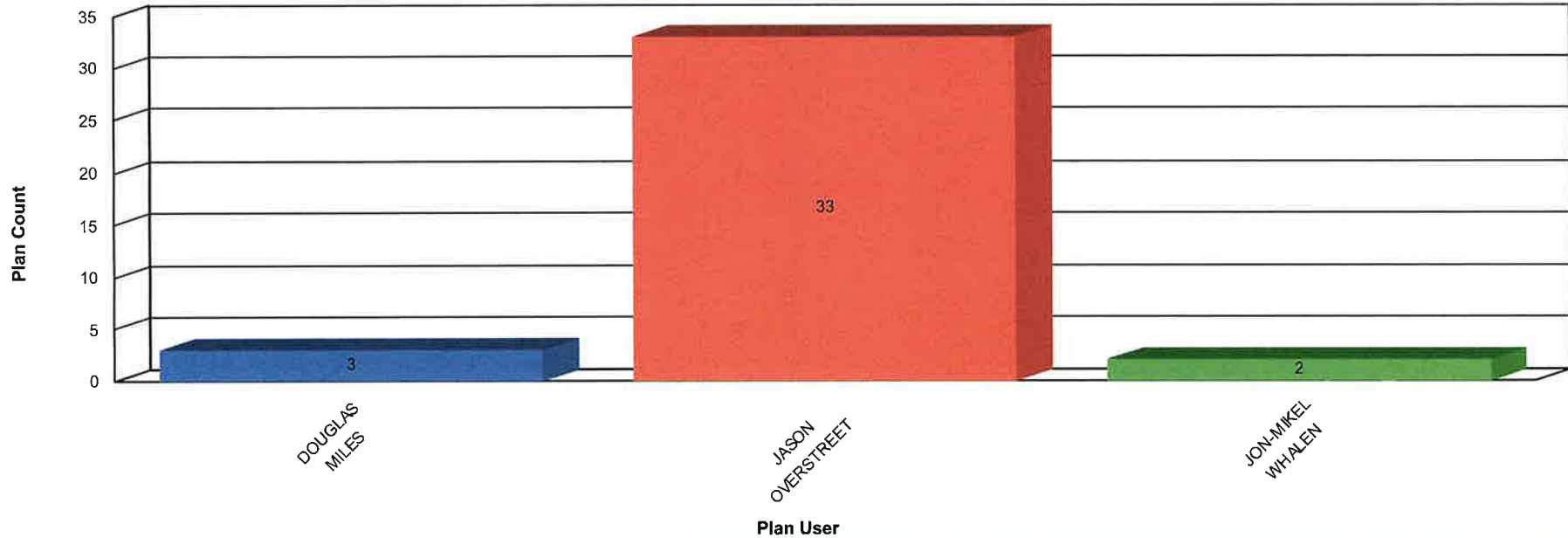

Plan Case #	Type	Workclass	Status	App Date	Main Address	Project	District	Parcel
<b>DOUGLAS MILES</b>								
MSC22:0012	Miscellaneous	Sign Permit	In Review	02/08/2022	1633 Kents Store Way, Kents Store, VA 23084	Not Assigned	Columbia	23 A 20
SDP22:0001	Site Development Plan	Site Development Plan - Major	In Review	02/11/2022		Not Assigned	Palmyra	8 A A14A3
SUB22:0007	Subdivision	Subdivision - Major	In Review	02/24/2022		Not Assigned	Palmyra	8 A A14A
<b>PLANS APPLIED FOR DOUGLAS MILES:</b>								<b>3</b>
<b>JASON OVERSTREET</b>								
MSC22:0005	Miscellaneous	Miscellaneous - Other	In Review	02/02/2022		Not Assigned	Columbia	32 15 4B
MSC22:0003	Miscellaneous	Miscellaneous - Other	In Review	02/02/2022		Not Assigned	Cunningham	18A 11 12
MSC22:0004	Miscellaneous	Miscellaneous - Other	In Review	02/02/2022		Not Assigned	Cunningham	18 A 38C
SUB22:0001	Subdivision	Subdivision - Family	In Review	02/02/2022	1491 Venable Rd, Palmyra, VA 22963	Not Assigned	Columbia	32 A 5

## PLANS APPLIED BY USER (02/01/2022 TO 02/28/2022)

Plan Case #	Type	Workclass	Status	App Date	Main Address	Project	District	Parcel
MSC22:0006	Miscellaneous	Miscellaneous - Other	Approved	02/03/2022	323 Broomsedge Dr, Troy, VA 22974	Not Assigned	Palmyra	10 A 12D
MSC22:0007	Miscellaneous	Miscellaneous - Other	Approved	02/03/2022	274 Double D Farm Trl, Palmyra, VA 22963	Not Assigned	Fork Union	29 A 81A
SUB22:0002	Subdivision	Subdivision - Major	In Review	02/03/2022		Not Assigned	Cunningham	8 A 18A
MSC22:0008	Miscellaneous	Miscellaneous - Other	Approved	02/03/2022		Not Assigned	Palmyra	18 16 18
MSC22:0009	Miscellaneous	Miscellaneous - Other	Approved	02/07/2022		Not Assigned	Fork Union	50 A 77
MSC22:0010	Miscellaneous	Miscellaneous - Other	Approved	02/07/2022		Not Assigned	Cunningham	16 A 9E
MSC22:0011	Miscellaneous	Miscellaneous - Other	Approved	02/08/2022	560 Deep Creek Rd, Palmyra, VA 22963	Not Assigned	Columbia	20 A 35A
SUB22:0003	Subdivision	Boundary Adjustment	In Review	02/09/2022	90 Parrish Ln, Kents Store, VA 23084	Not Assigned	Columbia	23 A 6
MSC22:0013	Miscellaneous	Miscellaneous - Other	Approved	02/10/2022	24 Plum Ct, Palmyra, VA 22963	Not Assigned	Cunningham	18 9 31
MSC22:0015	Miscellaneous	Miscellaneous - Other	Approved	02/11/2022		Not Assigned	Palmyra	18 16 16
MSC22:0014	Miscellaneous	Miscellaneous - Other	Approved	02/11/2022	8 Campbell Ct, Palmyra, VA 22963	Not Assigned	Rivanna	18A 2 135
MSC22:0016	Miscellaneous	Miscellaneous - Other	Approved	02/14/2022		Not Assigned	Columbia	44 5 20
SUB22:0004	Subdivision	Subdivision - Family	In Review	02/15/2022	2070 Rolling Rd S, Palmyra, VA 22963	Not Assigned	Cunningham	39 A 1
MSC22:0017	Miscellaneous	Miscellaneous - Other	Approved	02/16/2022	1171 North Boston Rd, Troy, VA 22974	Not Assigned	Palmyra	10 16 12
SUB22:0005	Subdivision	Boundary Adjustment	In Review	02/17/2022	1911 Oliver Creek Rd, Troy, VA 22974	Not Assigned	Palmyra	4 A 79B
SUB22:0006	Subdivision	Subdivision - Minor	In Review	02/17/2022	88 Maple Ln, Kents Store, VA 23084	Not Assigned	Columbia	14 1 2
MSC22:0018	Miscellaneous	Miscellaneous - Other	Approved	02/17/2022	325 Justin Dr, Palmyra, VA 22963	Not Assigned	Palmyra	18 12 101
MSC22:0019	Miscellaneous	Miscellaneous - Other	Approved	02/22/2022		Not Assigned	Columbia	31 19 7
MSC22:0020	Miscellaneous	Miscellaneous - Other	Approved	02/22/2022		Not Assigned	Columbia	31 19 22
MSC22:0021	Miscellaneous	Miscellaneous - Other	Approved	02/24/2022		Not Assigned	Fork Union	17 26 36
MSC22:0022	Miscellaneous	Miscellaneous - Other	Approved	02/24/2022		Not Assigned	Rivanna	18A 9 107

**PLANS APPLIED BY USER (02/01/2022 TO 02/28/2022)**

Plan Case #	Type	Workclass	Status	App Date	Main Address	Project	District	Parcel
MSC22:0023	Miscellaneous	Miscellaneous - Other	Approved	02/25/2022	3735 Cedar Lane Rd, Kents Store, VA 23084	Not Assigned	Columbia	33 7 4
SUB22:0008	Subdivision	Boundary Adjustment	In Review	02/25/2022		Not Assigned	Fork Union	29 A 117A
MSC22:0024	Miscellaneous	Miscellaneous - Other	In Review	02/28/2022		Not Assigned	Palmyra	18 16 49
MSC22:0025	Miscellaneous	Miscellaneous - Other	In Review	02/28/2022		Not Assigned	Palmyra	18 16 32
MSC22:0026	Miscellaneous	Miscellaneous - Other	In Review	02/28/2022		Not Assigned	Palmyra	18 16 31
MSC22:0028	Miscellaneous	Miscellaneous - Other	Approved	02/28/2022	67 Kathy Ct, Palmyra, VA 22963	Not Assigned	Palmyra	18 12 78
MSC22:0029	Miscellaneous	Miscellaneous - Other	In Review	02/28/2022	5526, Scottsville, VA 24590	Not Assigned	Cunningham	26 24 5
MSC22:0027	Miscellaneous	Miscellaneous - Other	In Review	02/28/2022		Not Assigned	Palmyra	18 16 22
<b>PLANS APPLIED FOR JASON OVERSTREET:</b>								<b>33</b>
<b>JON-MIKEL WHALEN</b>								
ZUP22:0001	Zoning Use Permits	Telecommunications Tower	Approved	02/02/2022	7021 James Madison Hwy, Fork Union, VA 23055	Not Assigned	Fork Union	52 1 7
ZUP22:0002	Zoning Use Permits	Telecommunications Tower	In Review	02/09/2022	30 Burns Plz, Palmyra, VA 22963	Not Assigned	Palmyra	8 A 30E
<b>PLANS APPLIED FOR JON-MIKEL WHALEN:</b>								<b>2</b>
<b>GRAND TOTAL OF PLANS:</b>								<b>38</b>